

**PLAN VIEW
(UPSIDE DOWN)**

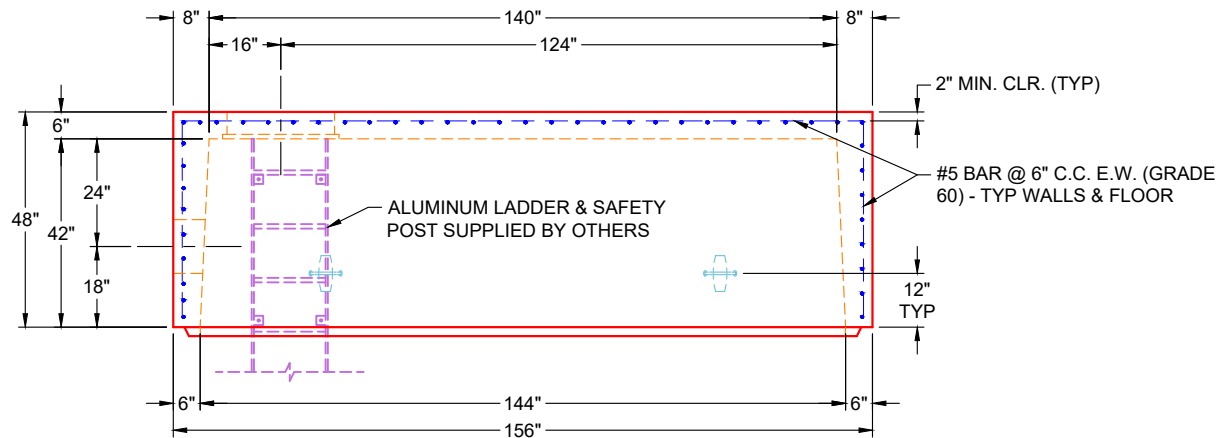

**VIEW A
(UPSIDE DOWN)**

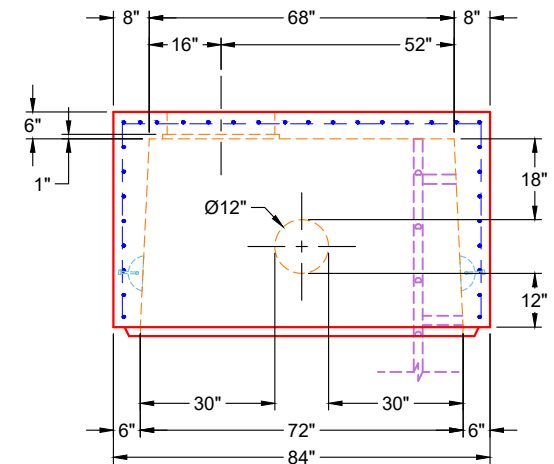

**VIEW B
(UPSIDE DOWN)**

GENERAL NOTES:

1. MANUFACTURED PER ASTM C-913 SPECIFICATIONS
2. CONCRETE: 5,000 PSI AT 28 DAYS
3. REINFORCEMENT: #5 BAR @ 6" C.C. E.W. (GRADE 60) - 2" MIN. REBAR CLEARANCE (TYP)
4. WEIGHT: 17,415 LBS
5. ALUMINUM LADDER & SAFETY POST SUPPLIED BY OTHERS
6. LINK-SEAL CONNECTORS SUPPLIED BY OTHERS
7. LIFTERS: 4 EA. 5CA14 CONAC A-ANCHORS FOR PLANT & FIELD HANDLING

PRODUCTION WORK ORDER

PRODUCT I.D.: BX072144-06W06F-VF

DESCRIPTION: 72" X 144" X 42" BASE, 6" WALLS & 6" FLOOR



QUALITY CONTROL CHECKLIST

- ALL DIMENSIONS CORRECT.
- LIFTERS INSTALLED.
- HOLE LOCATION(S) CORRECT.
- REINFORCING & SPACING CORRECT.
- SURFACE QUALITY ACCEPTABLE.
- EDGES CHAMFERED.
- JOINT INSTALLED.

PRODUCT VIEW: UPSIDE DOWN

CUSTOMER: STRIEGEL DESIGN & CONSTRUCTION

PLANT: BEAVER DAM, KY

PROJECT: 2025 NEW WELL FIELDS

WEIGHT: 17,415 LBS

STRUCTURE: 2-54406-12

TOP SECTION JOINT: N / A

ORDER NO: 25-4406

BASE SECTION JOINT: TONGUE

PE: J.H. ROSS

DRAWING: K. CARDWELL

QC CHECK INITIALS:

DATE: 02/11/26

SCALE: NTS

PG. 1 OF 1