

Job Name: 25-4404 - Old Heritage Subdivision Section 7
 Job Location: Shelbyville, KY 40065
 Contractor: Filcon Construction

Plant: 100

12/17/2025 2:02:27 PM

Tech: J. Horsley - F

PC: C. Goff



Structure ID: 38

P4 MH048CN30

ECC CONE w/ 24" HOLE F/G

- P5) 24" - CASTING HEIGHT - 7"
- P4) 48" - ECC CONE w/ 24" HOLE F/G - 30"
- P3) 48" - MH RISER w/DROP T/G - 48"
- P2) 48" - MH RISER w/DROP T/G - 48"
- P1) 48" - MH BASE w/DROP T/n - 24"
- 1) JOINT WRAP - 0.065"x6"x50' CONSEAL CS212
- 1) JOINT WRAP PRIMER - CONSEAL CS-75 (1 gal.)
- 1) 48" - MH INVERT CHANNEL - FULL HEIGHT
- 3) 48" - Conseal CS-102 1.00" (Double)
- 2) PSX - 12-08 NYLO
- 1) Drop Tee - 8" PVC
- 1) Drop Elbow - 8" PVC
- 13) MH Step ML-10-TDS-NCR - 10"

0 lb
 2050 lb
 3329 lb
 3353 lb
 2887 lb
 0 lb
 0 lb
 1440 lb
 0 lb
 16 lb
 0 lb
 0 lb
 0 lb
 0 lb

Structure Total: 13076 lb

- Structure Notes:
1. PER ASTM C-478 SPECIFICATIONS
 2. CONCRETE: 4,000 PSI AT 28 DAYS
 3. REINFORCEMENT: PER ASTM A615
 4. INVERT CHANNEL REQUIRED
 5. STEPS AT 0 DEGREES
 6. CASTING SUPPLIED BY OTHERS

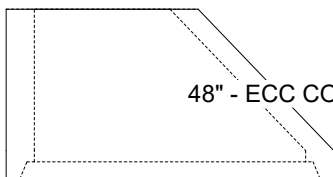
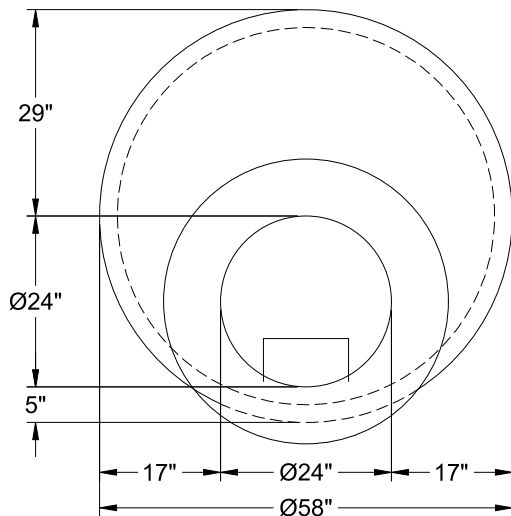

48" - ECC CONE w/ 24" HOLE F/G - 30" - (P4)

Coating (Int):
 Coating (Ext):

Seam Up: Flat
 Seam Dn: Groove

Wall Thickness: 5"

Height (Ext): 30"

Weight (Net): 2050 lb
 Volume (Net): 0.41cu.yd