

Job Name: 25-4404 - Old Heritage Subdivision Section 7  
 Job Location: Shelbyville, KY 40065  
 Contractor: Filcon Construction

Plant: 100

12/17/2025 2:01:08 PM

Tech: J. Horsley - F

PC: C. Goff



**Structure ID: 38**

**P1 MH048BA24**

**MH BASE w/DROP T/n**

- P5) 24" - CASTING HEIGHT - 7"
- P4) 48" - ECC CONE w/ 24" HOLE F/G - 30"
- P3) 48" - MH RISER w/DROP T/G - 48"
- P2) 48" - MH RISER w/DROP T/G - 48"
- P1) 48" - MH BASE w/DROP T/n - 24"
- 1) JOINT WRAP - 0.065"x6"x50' CONSEAL CS212
- 1) JOINT WRAP PRIMER - CONSEAL CS-75 (1 gal.)
- 1) 48" - MH INVERT CHANNEL - FULL HEIGHT
- 3) 48" - Conseal CS-102 1.00" (Double)
- 2) PSX - 12-08 NYLO
- 1) Drop Tee - 8" PVC
- 1) Drop Elbow - 8" PVC
- 13) MH Step ML-10-TDS-NCR - 10"

0 lb  
 2050 lb  
 5393 lb  
 5417 lb  
 4177 lb  
 0 lb  
 0 lb  
 1440 lb  
 0 lb  
 16 lb  
 0 lb  
 0 lb  
 0 lb  
 0 lb  
 Structure Total: 18493 lb

- Structure Notes:**
1. PER ASTM C-478 SPECIFICATIONS
  2. CONCRETE: 4,000 PSI AT 28 DAYS
  3. REINFORCEMENT: PER ASTM A615
  4. INVERT CHANNEL REQUIRED
  5. STEPS AT 0 DEGREES
  6. CASTING SUPPLIED BY OTHERS
  7. EXTERNAL DROP AT INVERTS 3 & 4 SUPPLIED BY ICAST
  8. ADD 8" SDR 35 DROP & ELBOW AT INVERT 4

Rim: 787.02' Rim to Invert: 12.92' Slack: 1.04" Sump: 3" Step Position: 0°

Position	Elev	Angle	Ext. (cw)	Pipe	Pipe OD	Connector	Hole	Horz Size	Up ( )	Offset
Invert 1	774.1'	0°	0"	8" PVC SDR35	8.5"	PSX 12-08 NYLO	12"	12.129"	1"	0"
Invert 2	774.2'	96°	48.59"	8" PVC SDR35	8.5"	PSX 12-08 NYLO	12"	12.129"	2.2"	0"
Invert 3										
Invert 4	774.2'	195°	98.698"	8" PVC SDR35	8.5"	Drop Elbow 8" PVC	8.5"	8.545"	3.95"	0"
Invert 5										
Invert 6										
Invert 7										
Invert 8										

RIGHT-SIDE UP VIEW (int. dimensions)

UPSIDE-DOWN VIEW (int. dimensions)

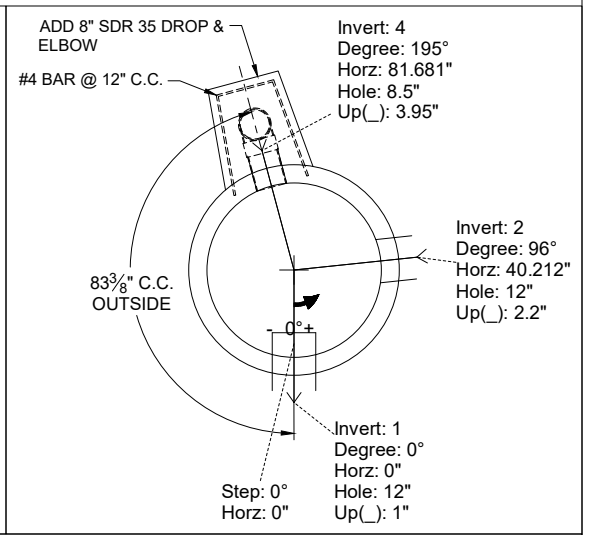
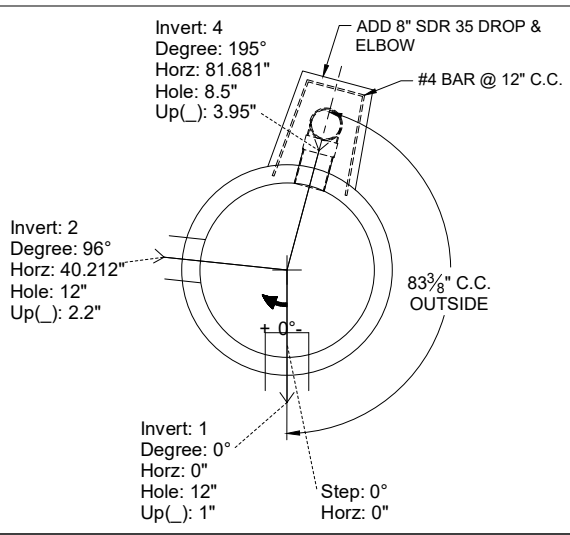
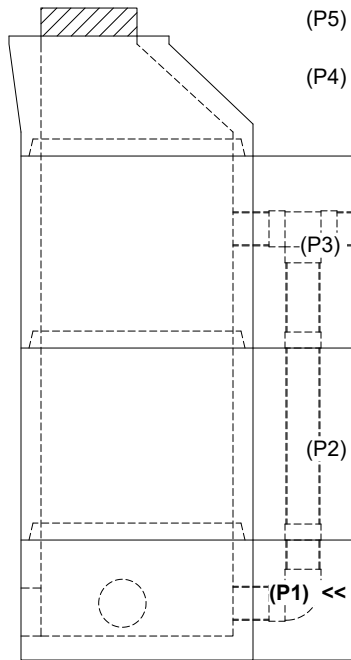

INSIDE WALL DIMENSIONS

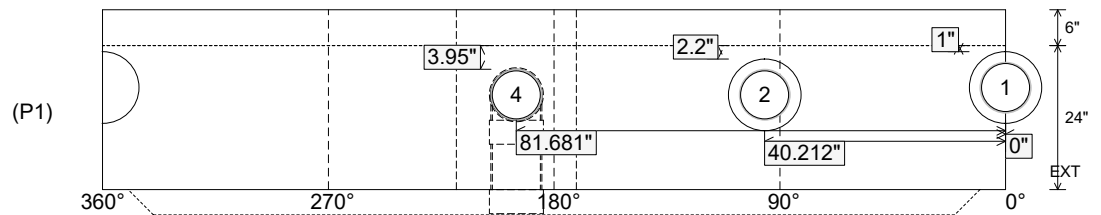

Coating (Int):  
 Coating (Ext):

Seam Up: Tongue  
 Seam Dn: n/a

Wall Thickness: 5"  
 Floor Height: 6"

Height (Int): 24"  
 Height (Ext): 30"

Weight (Net): 2887 lb  
 Volume (Net): 0.74cu.yd

**Structure ID: 38**

**P1 MH048BA24**

**MH BASE w/DROP T/n**

P5) 24" - CASTING HEIGHT - 7" P4) 48" - ECC CONE w/ 24" HOLE F/G - 30" P3) 48" - MH RISER w/DROP T/G - 48" P2) 48" - MH RISER w/DROP T/G - 48" P1) 48" - MH BASE w/DROP T/n - 24" 1) JOINT WRAP - 0.065"x6"x50' CONSEAL CS212 1) JOINT WRAP PRIMER - CONSEAL CS-75 (1 gal.) 1) 48" - MH INVERT CHANNEL - FULL HEIGHT 3) 48" - Conseal CS-102 1.00" (Double) 2) PSX - 12-08 NYLO 1) Drop Tee - 8" PVC 1) Drop Elbow - 8" PVC 13) MH Step ML-10-TDS-NCR - 10"	0 lb 2050 lb 5393 lb 5417 lb 4177 lb 0 lb 0 lb 1440 lb 0 lb 16 lb 0 lb 0 lb 0 lb 0 lb 18493 lb	<b>Structure Notes:</b> 1. PER ASTM C-478 SPECIFICATIONS 2. CONCRETE: 4,000 PSI AT 28 DAYS 3. REINFORCEMENT: PER ASTM A615 4. INVERT CHANNEL REQUIRED 5. STEPS AT 0 DEGREES 6. CASTING SUPPLIED BY OTHERS 7. EXTERNAL DROP AT INVERTS 3 & 4 SUPPLIED BY ICAST
Structure Total:		

Rim: 787.02'    Rim to Invert: 12.92'    Slack: 1.04"    Sump: 3"    Step Position: 0°

Position	Elev	Angle	Ext. (cw)	Pipe	Pipe OD	Connector	Hole	Horz Size	Up ( )	Offset
Invert 1	774.1'	0°	0"	8" PVC SDR35	8.5"	PSX 12-08 NYLO	12"	12.129"	1"	0"
Invert 2	774.2'	96°	48.59"	8" PVC SDR35	8.5"	PSX 12-08 NYLO	12"	12.129"	2.2"	0"
Invert 3										
Invert 4	774.2'	195°	98.698"	8" PVC SDR35	8.5"	Drop Elbow 8" PVC	8.5"	8.545"	3.95"	0"
Invert 5										
Invert 6										
Invert 7										
Invert 8										

**RIGHT-SIDE UP VIEW (int. dimensions)      UPSIDE-DOWN VIEW (int. dimensions)**

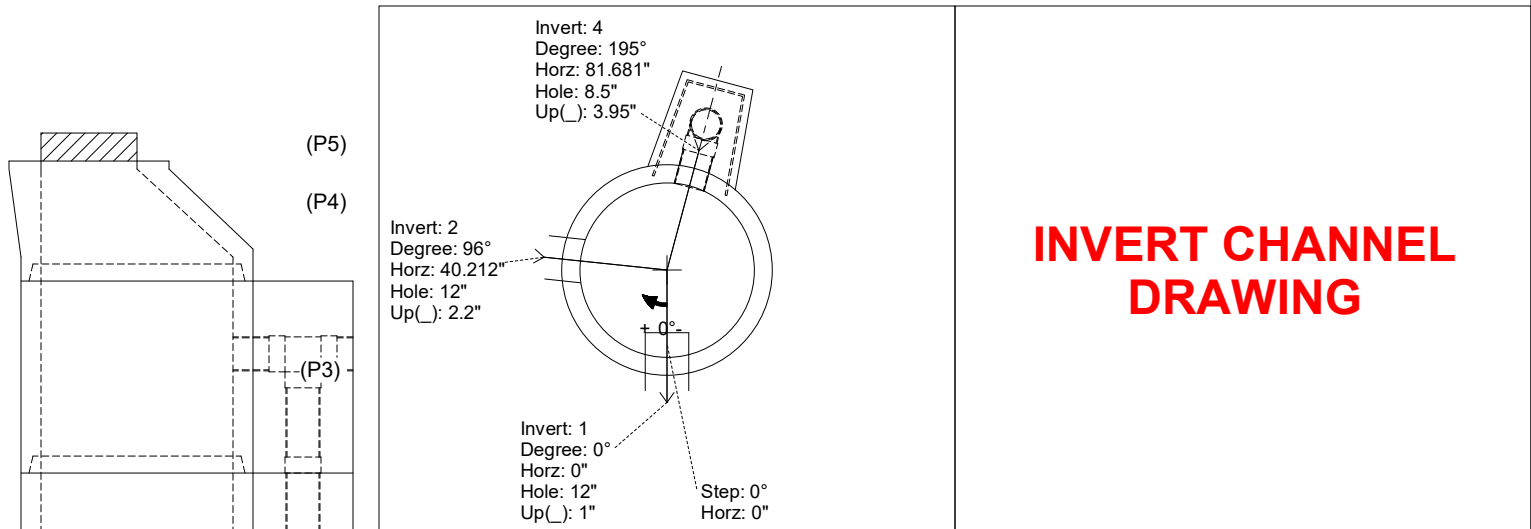

**INSIDE WALL DIMENSIONS**

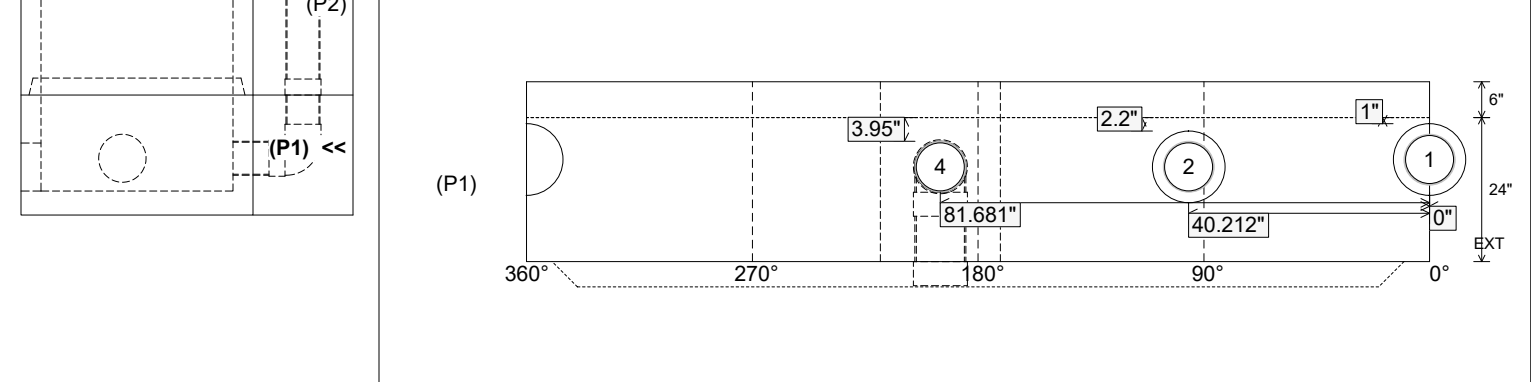

Coating (Int): Coating (Ext):	Seam Up: Tongue Seam Dn: n/a	Wall Thickness: 5" Floor Height: 6"	Height (Int): 24" Height (Ext): 30"	Weight (Net): 2887 lb Volume (Net): 0.74cu.yd
----------------------------------	---------------------------------	--	--	--