

Job Name: 25-4404 - Old Heritage Subdivision Section 7
 Job Location: Shelbyville, KY 40065
 Contractor: Filcon Construction

Plant: 100

12/17/2025 2:01:04 PM

Tech: J. Horsley - F

PC: C. Goff



Structure ID: 14+11.37

P1 MH060BAVF

MH BASE Custom Ht T/n

- P3) 24" x 44" - CASTING HEIGHT - 3.50"
- P2) 60" - MH FLAT TOP w/24"x44" Hole F/G - 13"
- P1) 60" - MH BASE Custom Ht T/n - 45"
- 1) 60" - Conseal CS-102 1.00"
- 2) Hole - 30
- 4) MH Step ML-10-TDS-NCR - 10"

0 lb
 2347 lb
 6691 lb
 0 lb
 0 lb
 0 lb

 9038 lb

Structure Total: 9038 lb

- Structure Notes:**
1. PER ASTM C-478 SPECIFICATIONS
 2. CONCRETE: 4,000 PSI AT 28 DAYS
 3. REINFORCEMENT: PER ASTM A615
 4. STEPS AT 135 DEGREES
 5. NO INVERT CHANNEL
 6. CASTING SUPPLIED BY OTHERS

Rim: 798.82' Rim to Invert: 5.18' Slack: 0.66" Sump: 0" Step Position: 135°

| Position | Elev | Angle | Ext. (cw) | Pipe | Pipe OD | Connector | Hole | Horz Size | Up () | Offset |
|----------|---------|-------|-----------|----------|---------|-----------|------|-----------|--------|--------|
| Invert 1 | 793.64' | 0° | 0" | 24" HDPE | 27.8" | Hole 30 | 30" | 31.416" | -1.9" | 0" |
| Invert 2 | 793.64' | 270° | 169.646" | 24" HDPE | 27.8" | Hole 30 | 30" | 31.416" | -1.9" | 0" |
| Invert 3 | | | | | | | | | | |
| Invert 4 | | | | | | | | | | |
| Invert 5 | | | | | | | | | | |
| Invert 6 | | | | | | | | | | |
| Invert 7 | | | | | | | | | | |
| Invert 8 | | | | | | | | | | |

RIGHT-SIDE UP VIEW (int. dimensions)

UPSIDE-DOWN VIEW (int. dimensions)

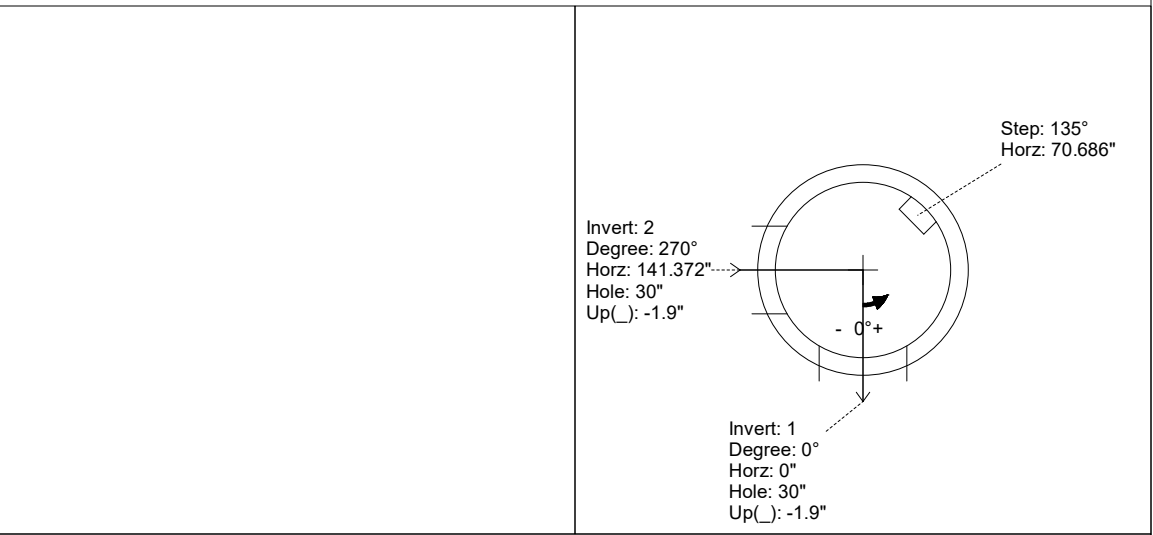
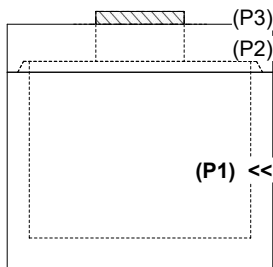

INSIDE WALL DIMENSIONS

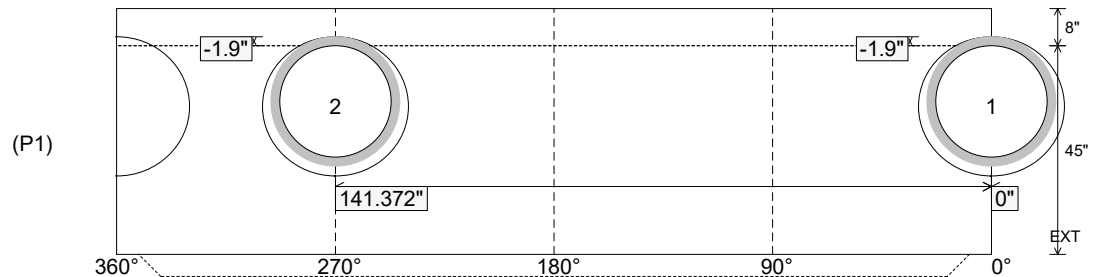

Coating (Int):
 Coating (Ext):

Seam Up: Tongue
 Seam Dn: n/a

Wall Thickness: 6"
 Floor Height: 8"

Height (Int): 45"
 Height (Ext): 53"

Weight (Net): 6691 lb
 Volume (Net): 1.71cu.yd