

Job Name: 25-4404 - Old Heritage Subdivision Section 7  
 Job Location: Shelbyville, KY 40065  
 Contractor: Filcon Construction

Plant: 100

12/17/2025 2:02:24 PM

Tech: J. Horsley - F

PC: C. Goff



**Structure ID: 13+90.22**

**P2 MH060LD13SP**

**MH FLAT TOP w/24"x44" Hole F/G**

- P3) 24" x 44" - CASTING HEIGHT - 3.50"
- P2) 60" - MH FLAT TOP w/24"x44" Hole F/G - 13"
- P1) 60" - MH BASE T/n - 48"
- 1) 60" - Conseal CS-102 1.00"
- 2) Hole - 30
- 4) MH Step ML-10-TDS-NCR - 10"

0 lb  
 2347 lb  
 7004 lb  
 0 lb  
 0 lb  
 0 lb  
 -----  
 9351 lb

Structure Total: 9351 lb

- Structure Notes:**
1. PER ASTM C-478 SPECIFICATIONS
  2. CONCRETE: 4,000 PSI AT 28 DAYS
  3. REINFORCEMENT: #5 BAR @ 6" C.C. E.W. (GRADE 60) - 2" MIN. REBAR CLEARANCE (TYP)
  4. STEPS AT 223.5 DEGREES
  5. NO INVERT CHANNEL
  6. CASTING SUPPLIED BY OTHERS
  7. LIFTERS: 4 EA. WRA016 CONAC WIRE ROPE ANCHORS FOR PLANT & FIELD HANDLING

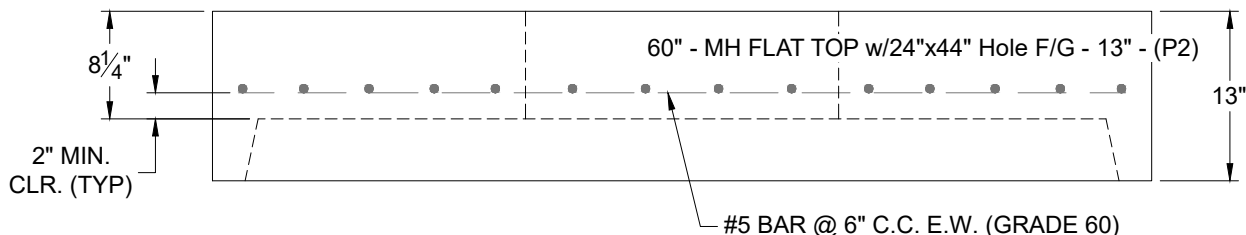
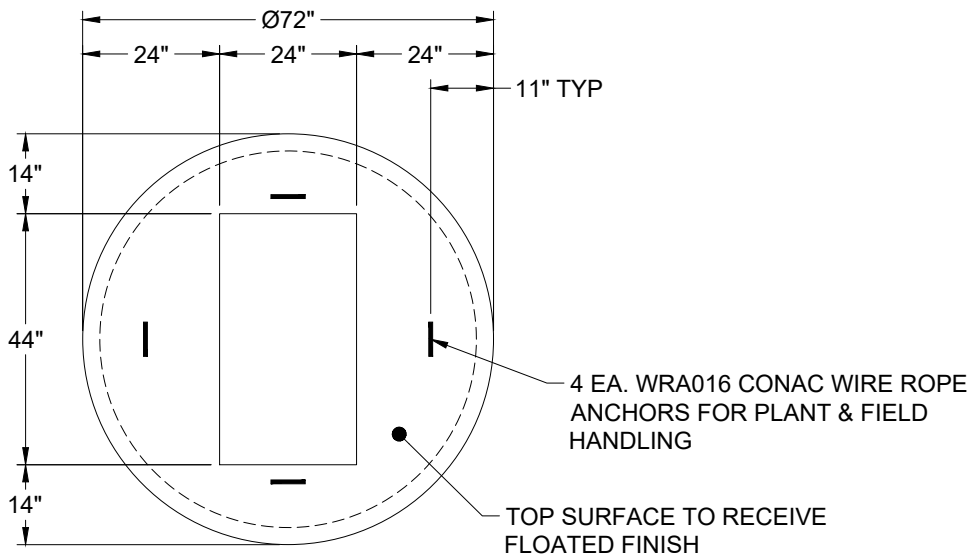

Coating (Int):  
 Coating (Ext):

Seam Up: Flat  
 Seam Dn: Groove

Wall Thickness: 6"

Height (Ext): 13"

Weight (Net): 2347 lb  
 Volume (Net): 0.6cu.yd