

Job Name: 25-4403 - Old Heritage Subdivision Section 6
 Job Location: Shelbyville, KY 40065
 Contractor: Filcon Construction

Plant: 100

1/3/2026 11:37:58 AM

Tech: J. Horsey - F

PC: C. Goff



Structure ID: 52

P2 MH048CN42

ECC CONE w/ 24" HOLE F/G

- P3) 24" - CASTING HEIGHT - 7"
- P2) 48" - ECC CONE w/ 24" HOLE F/G - 42"
- P1) 48" - MH BASE T/n - 36"
- 1) JOINT WRAP - 0.065"x6"x50' CONSEAL CS212
- 1) JOINT WRAP PRIMER - CONSEAL CS-75 (1 gal.)
- 1) 48" - MH INVERT CHANNEL - FULL HEIGHT
- 1) 48" - Conseal CS-102 1.00" (Double)
- 2) PSX - 12-08 NYLO
- 2) PSX - 12-06 NYLO
- 6) MH Step ML-10-TDS-NCR - 10"

- 0 lb
- 3200 lb
- 3654 lb
- 0 lb
- 0 lb
- 1440 lb
- 0 lb
- 16 lb
- 16 lb
- 0 lb

Structure Total: 8326 lb

- Structure Notes:
1. PER ASTM C-478 SPECIFICATIONS
 2. CONCRETE: 4,000 PSI AT 28 DAYS
 3. REINFORCEMENT: PER ASTM A615
 4. INVERT CHANNEL REQUIRED
 5. STEPS AT 0 DEGREES
 6. CASTING SUPPLIED BY OTHERS

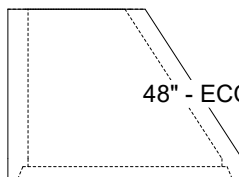
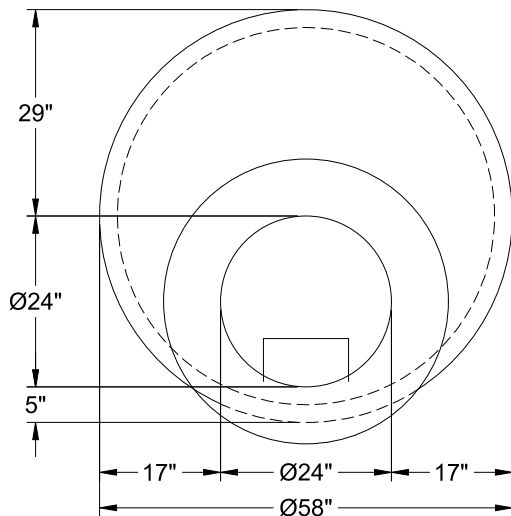

48" - ECC CONE w/ 24" HOLE F/G - 42" - (P2)

Coating (Int):
 Coating (Ext):

Seam Up: Flat
 Seam Dn: Groove

Wall Thickness: 5"

Height (Ext): 42"

Weight (Net): 3200 lb
 Volume (Net): 0.5cu.yd