

Job Name: 25-4403 - Old Heritage Subdivision Section 6  
 Job Location: Shelbyville, KY 40065  
 Contractor: Filcon Construction

Plant: 100

1/3/2026 11:37:59 AM

Tech: J. Horsey - F

PC: C. Goff



**Structure ID: 50**

**P4 GR3**

**GRADE RING F/F**

- P5) 24" - CASTING HEIGHT - 7"
- P4) 24" - GRADE RING F/F - 3"
- P3) 48" - ECC CONE w/ 24" HOLE F/G - 36"
- P2) 48" - MH RISER T/G - 24"
- P1) 48" - MH BASE T/n - 24"

- 1) JOINT WRAP - 0.065"x6"x50' CONSEAL CS212
- 1) JOINT WRAP PRIMER - CONSEAL CS-75 (1 gal.)
- 1) 48" - MH INVERT CHANNEL - FULL HEIGHT
- 2) 48" - Conseal CS-102 1.00" (Double)
- 2) PSX - 12-08 NYLO
- 1) PSX - 12-06 NYLO
- 6) MH Step ML-10-TDS-NCR - 10"

0 lb  
 202 lb  
 3000 lb  
 1677 lb  
 2863 lb  
 0 lb  
 0 lb  
 1440 lb  
 0 lb  
 16 lb  
 8 lb  
 0 lb  
 -----  
 Structure Total: 9206 lb

**Structure Notes:**  
 1. PER ASTM C-478 SPECIFICATIONS  
 2. CONCRETE: 4,000 PSI AT 28 DAYS  
 3. REINFORCEMENT: (1) #3 HOOP CENTERED (GRADE 60)

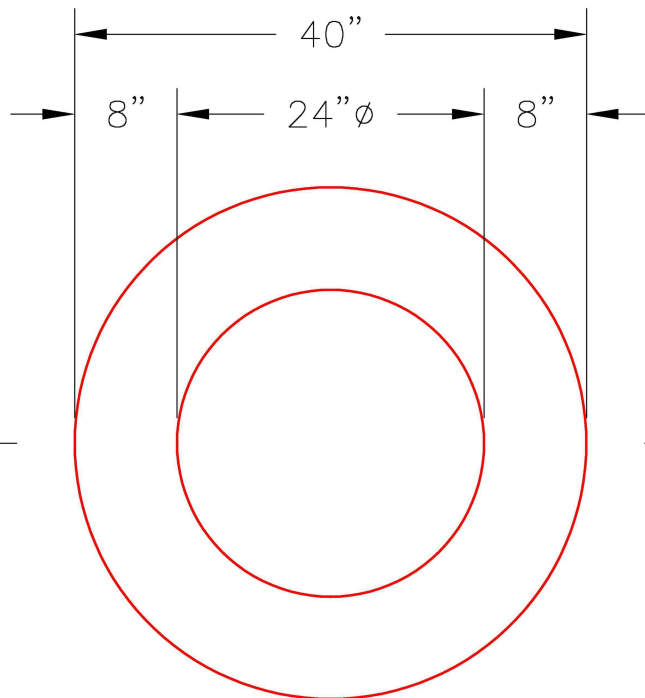

**PLAN VIEW**

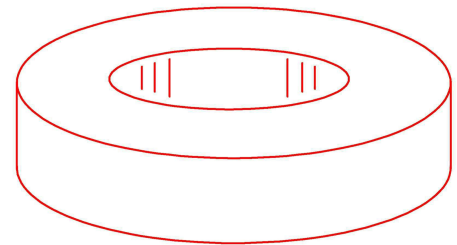

**ISOMETRIC VIEW**

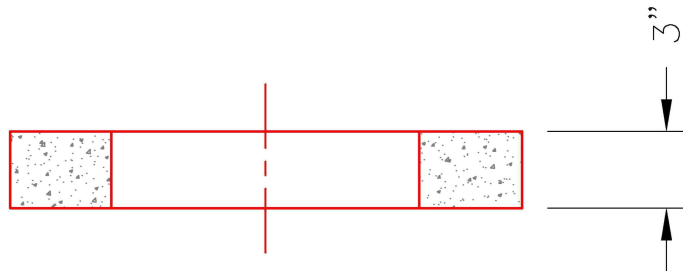

**SECTION A-A**

Coating (Int):  
 Coating (Ext):

Seam Up: Flat  
 Seam Dn: Flat

Wall Thickness: 8"

Height (Ext): 3"

Weight (Net): 202 lb  
 Volume (Net): 0.05cu.yd