

Job Name: 25-4403 - Old Heritage Subdivision Section 6
 Job Location: Shelbyville, KY 40065
 Contractor: Filcon Construction

Plant: 100

Tech: J. Horsey - F

1/3/2026 11:37:10 AM

PC: C. Goff



Structure ID: 50

P1 MH048BA24

MH BASE T/n

- P5) 24" - CASTING HEIGHT - 7"
- P4) 24" - GRADE RING F/F - 3"
- P3) 48" - ECC CONE w/ 24" HOLE F/G - 36"
- P2) 48" - MH RISER T/G - 24"
- P1) 48" - MH BASE T/n - 24"
- 1) JOINT WRAP - 0.065"x6"x50' CONSEAL CS212
- 1) JOINT WRAP PRIMER - CONSEAL CS-75 (1 gal.)
- 1) 48" - MH INVERT CHANNEL - FULL HEIGHT
- 2) 48" - Conseal CS-102 1.00" (Double)
- 2) PSX - 12-08 NYLO
- 1) PSX - 12-06 NYLO
- 6) MH Step ML-10-TDS-NCR - 10"

0 lb
 202 lb
 3000 lb
 1677 lb
 2863 lb
 0 lb
 0 lb
 1440 lb
 0 lb
 16 lb
 8 lb
 0 lb

 Structure Total: 9206 lb

- Structure Notes:**
1. PER ASTM C-478 SPECIFICATIONS
 2. CONCRETE: 4,000 PSI AT 28 DAYS
 3. REINFORCEMENT: PER ASTM A615
 4. INVERT CHANNEL REQUIRED
 5. STEPS AT 0 DEGREES
 6. CASTING SUPPLIED BY OTHERS

Rim: 776.62' Rim to Invert: 7.63' Slack: 0.56" Sump: 3" Step Position: 0°

Position	Elev	Angle	Ext. (cw)	Pipe	Pipe OD	Connector	Hole	Horz Size	Up ()	Offset
Invert 1	768.99'	0°	0"	8" PVC SDR35	8.5"	PSX 12-08 NYLO	12"	12.129"	1"	0"
Invert 2	769.49'	109°	55.17"	6" PVC SDR35	6.25"	PSX 12-06 NYLO	12"	12.129"	6"	0"
Invert 3	769.09'	217°	109.834"	8" PVC SDR35	8.5"	PSX 12-08 NYLO	12"	12.129"	2.2"	0"
Invert 4										
Invert 5										
Invert 6										
Invert 7										
Invert 8										

RIGHT-SIDE UP VIEW (int. dimensions)

UPSIDE-DOWN VIEW (int. dimensions)

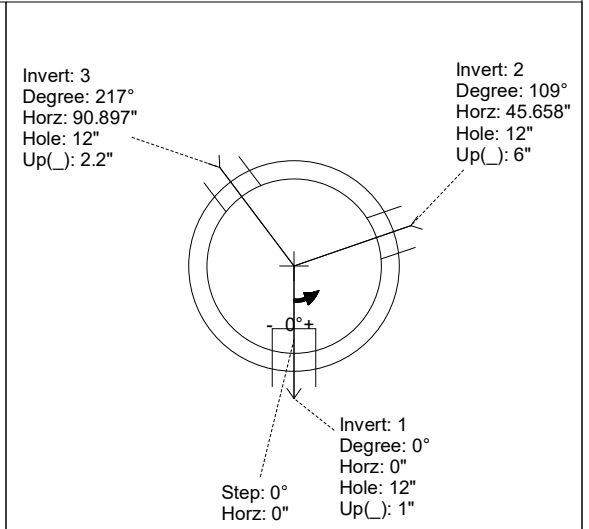
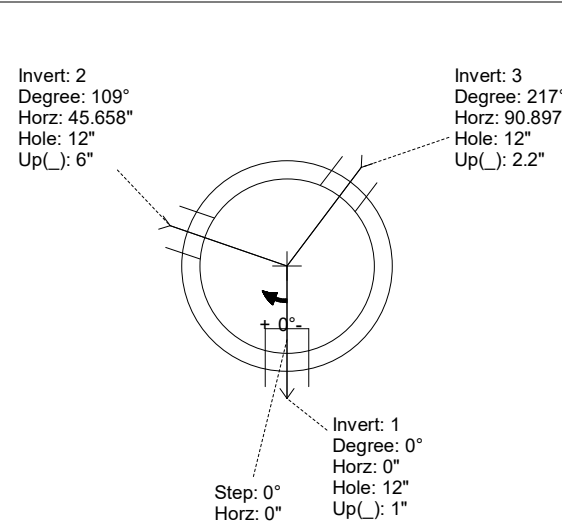
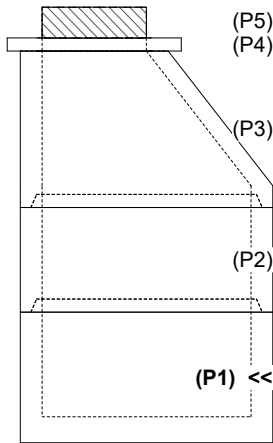

INSIDE WALL DIMENSIONS

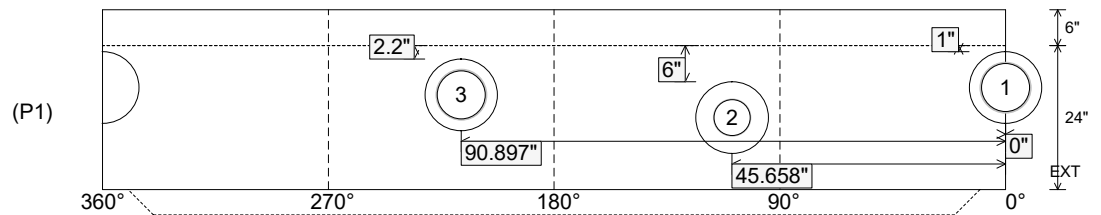

Coating (Int):
 Coating (Ext):

Seam Up: Tongue
 Seam Dn: n/a

Wall Thickness: 5"
 Floor Height: 6"

Height (Int): 24"
 Height (Ext): 30"

Weight (Net): 2863 lb
 Volume (Net): 0.73cu.yd

Structure ID: 50

P1 MH048BA24

MH BASE T/n

P5) 24" - CASTING HEIGHT - 7" P4) 24" - GRADE RING F/F - 3" P3) 48" - ECC CONE w/ 24" HOLE F/G - 36" P2) 48" - MH RISER T/G - 24" P1) 48" - MH BASE T/n - 24" 1) JOINT WRAP - 0.065"x6"x50' CONSEAL CS212 1) JOINT WRAP PRIMER - CONSEAL CS-75 (1 gal.) 1) 48" - MH INVERT CHANNEL - FULL HEIGHT 2) 48" - Conseal CS-102 1.00" (Double) 2) PSX - 12-08 NYLO 1) PSX - 12-06 NYLO 6) MH Step ML-10-TDS-NCR - 10"	0 lb 202 lb 3000 lb 1677 lb 2863 lb 0 lb 0 lb 1440 lb 0 lb 16 lb 8 lb 0 lb ----- Structure Total: 9206 lb	Structure Notes: 1. PER ASTM C-478 SPECIFICATIONS 2. CONCRETE: 4,000 PSI AT 28 DAYS 3. REINFORCEMENT: PER ASTM A615 4. INVERT CHANNEL REQUIRED 5. STEPS AT 0 DEGREES 6. CASTING SUPPLIED BY OTHERS
---	--	---

Rim: 776.62' Rim to Invert: 7.63' Slack: 0.56" Sump: 3" Step Position: 0°

Position	Elev	Angle	Ext. (cw)	Pipe	Pipe OD	Connector	Hole	Horz Size	Up ()	Offset
Invert 1	768.99'	0°	0"	8" PVC SDR35	8.5"	PSX 12-08 NYLO	12"	12.129"	1"	0"
Invert 2	769.49'	109°	55.17"	6" PVC SDR35	6.25"	PSX 12-06 NYLO	12"	12.129"	6"	0"
Invert 3	769.09'	217°	109.834"	8" PVC SDR35	8.5"	PSX 12-08 NYLO	12"	12.129"	2.2"	0"
Invert 4										
Invert 5										
Invert 6										
Invert 7										
Invert 8										

RIGHT-SIDE UP VIEW (int. dimensions)

UPSIDE-DOWN VIEW (int. dimensions)

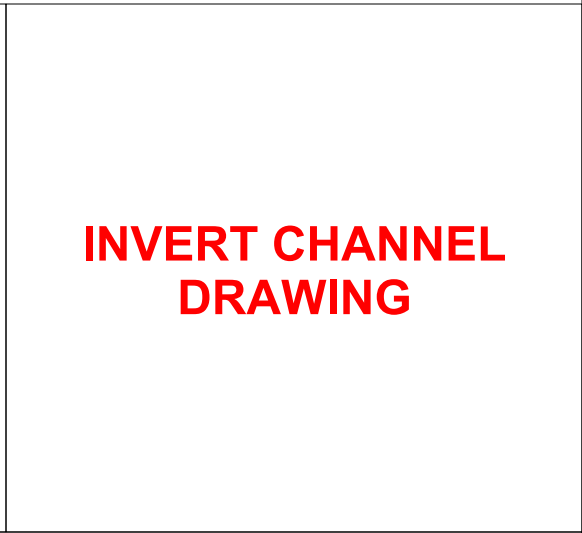
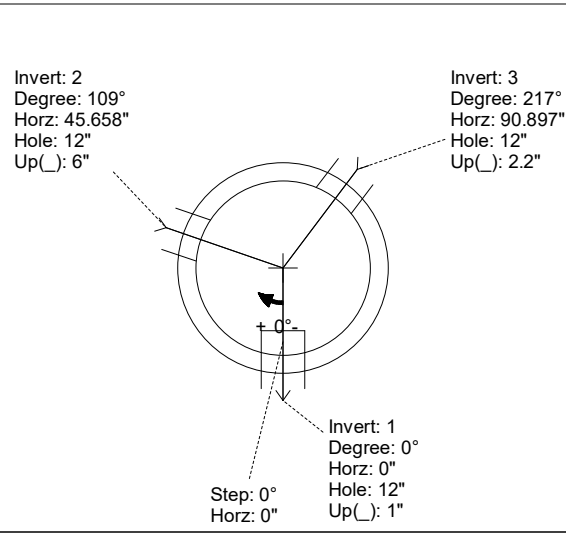
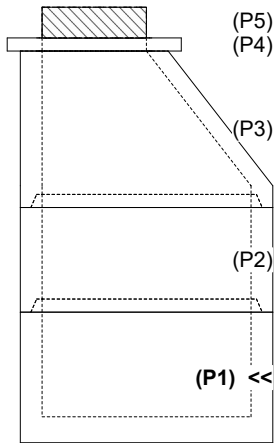

INVERT CHANNEL DRAWING

INSIDE WALL DIMENSIONS

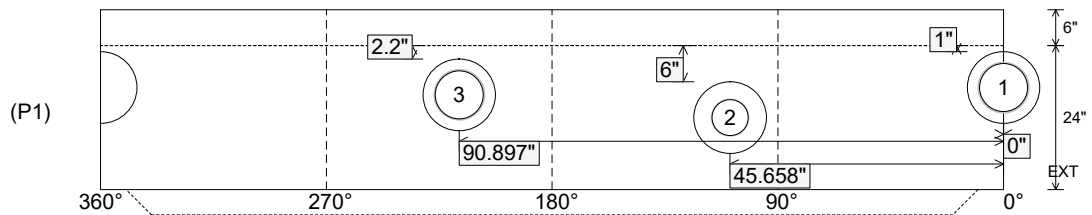

Coating (Int): Coating (Ext):	Seam Up: Tongue Seam Dn: n/a	Wall Thickness: 5" Floor Height: 6"	Height (Int): 24" Height (Ext): 30"	Weight (Net): 2863 lb Volume (Net): 0.73cu.yd
----------------------------------	---------------------------------	--	--	--