

Job Name: 25-4403 - Old Heritage Subdivision Section 6  
 Job Location: Shelbyville, KY 40065  
 Contractor: Filcon Construction

Plant: 100

Tech: J. Horsey - F

1/3/2026 11:37:11 AM

PC: C. Goff



**Structure ID: 48**

**P1 MH048BA24**

**MH BASE T/n**

- P4) 24" - CASTING HEIGHT - 7"
- P3) 48" - ECC CONE w/ 24" HOLE F/G - 30"
- P2) 48" - MH RISER T/G - 36"
- P1) 48" - MH BASE T/n - 24"
- 1) JOINT WRAP - 0.065"x6"x50' CONSEAL CS212
- 1) JOINT WRAP PRIMER - CONSEAL CS-75 (1 gal.)
- 1) 48" - MH INVERT CHANNEL - FULL HEIGHT
- 2) 48" - Conseal CS-102 1.00" (Double)
- 3) PSX - 12-08 NYLO
- 7) MH Step ML-10-TDS-NCR - 10"

0 lb  
 2050 lb  
 2515 lb  
 2863 lb  
 0 lb  
 0 lb  
 1440 lb  
 0 lb  
 24 lb  
 0 lb  
 -----  
 Structure Total: 8892 lb

- Structure Notes:**
1. PER ASTM C-478 SPECIFICATIONS
  2. CONCRETE: 4,000 PSI AT 28 DAYS
  3. REINFORCEMENT: PER ASTM A615
  4. INVERT CHANNEL REQUIRED
  5. STEPS AT 0 DEGREES
  6. CASTING SUPPLIED BY OTHERS

Rim: 777.87' Rim to Invert: 7.86' Slack: 0.32" Sump: 3" Step Position: 0°

Position	Elev	Angle	Ext. (cw)	Pipe	Pipe OD	Connector	Hole	Horz Size	Up ( )	Offset
Invert 1	770.01'	0°	0"	8" PVC SDR35	8.5"	PSX 12-08 NYLO	12"	12.129"	1"	0"
Invert 2	770.11'	139°	70.354"	8" PVC SDR35	8.5"	PSX 12-08 NYLO	12"	12.129"	2.2"	0"
Invert 3	770.11'	280°	141.721"	8" PVC SDR35	8.5"	PSX 12-08 NYLO	12"	12.129"	2.2"	0"
Invert 4										
Invert 5										
Invert 6										
Invert 7										
Invert 8										

RIGHT-SIDE UP VIEW (int. dimensions)

UPSIDE-DOWN VIEW (int. dimensions)

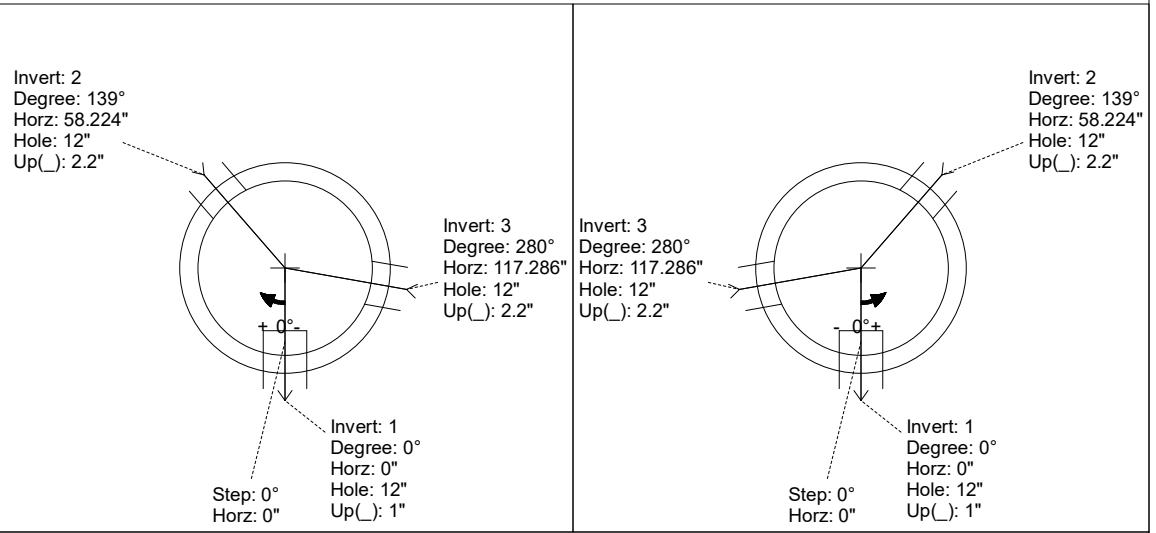

INSIDE WALL DIMENSIONS

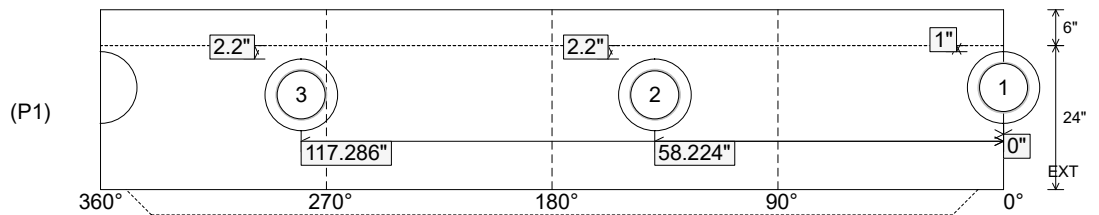

Coating (Int):  
 Coating (Ext):

Seam Up: Tongue  
 Seam Dn: n/a

Wall Thickness: 5"  
 Floor Height: 6"

Height (Int): 24"  
 Height (Ext): 30"

Weight (Net): 2863 lb  
 Volume (Net): 0.73cu.yd

**Structure ID: 48**

**P1 MH048BA24**

**MH BASE T/n**

P4) 24" - CASTING HEIGHT - 7" P3) 48" - ECC CONE w/ 24" HOLE F/G - 30" P2) 48" - MH RISER T/G - 36" P1) 48" - MH BASE T/n - 24" 1) JOINT WRAP - 0.065"x6"x50' CONSEAL CS212 1) JOINT WRAP PRIMER - CONSEAL CS-75 (1 gal.) 1) 48" - MH INVERT CHANNEL - FULL HEIGHT 2) 48" - Conseal CS-102 1.00" (Double) 3) PSX - 12-08 NYLO 7) MH Step ML-10-TDS-NCR - 10"	0 lb 2050 lb 2515 lb 2863 lb 0 lb 0 lb 1440 lb 0 lb 24 lb 0 lb ----- Structure Total: 8892 lb
---	--

**Structure Notes:**

1. PER ASTM C-478 SPECIFICATIONS
2. CONCRETE: 4,000 PSI AT 28 DAYS
3. REINFORCEMENT: PER ASTM A615
4. INVERT CHANNEL REQUIRED
5. STEPS AT 0 DEGREES
6. CASTING SUPPLIED BY OTHERS

Rim: 777.87'    Rim to Invert: 7.86'    Slack: 0.32"    Sump: 3"    Step Position: 0°

Position	Elev	Angle	Ext. (cw)	Pipe	Pipe OD	Connector	Hole	Horz Size	Up ( )	Offset
Invert 1	770.01'	0°	0"	8" PVC SDR35	8.5"	PSX 12-08 NYLO	12"	12.129"	1"	0"
Invert 2	770.11'	139°	70.354"	8" PVC SDR35	8.5"	PSX 12-08 NYLO	12"	12.129"	2.2"	0"
Invert 3	770.11'	280°	141.721"	8" PVC SDR35	8.5"	PSX 12-08 NYLO	12"	12.129"	2.2"	0"
Invert 4										
Invert 5										
Invert 6										
Invert 7										
Invert 8										

RIGHT-SIDE UP VIEW (int. dimensions)

UPSIDE-DOWN VIEW (int. dimensions)

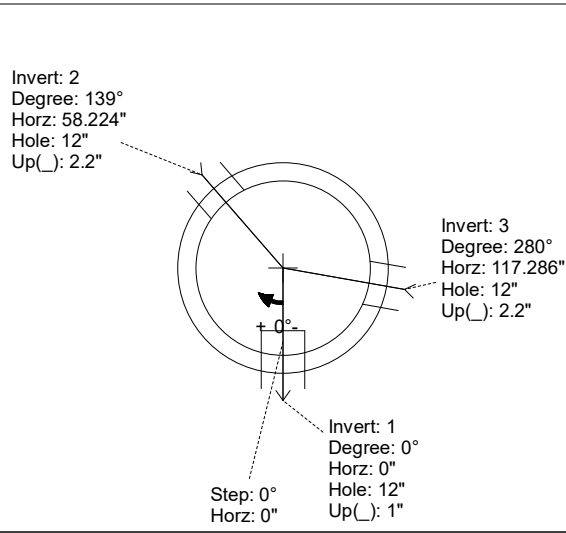

INVERT CHANNEL DRAWING

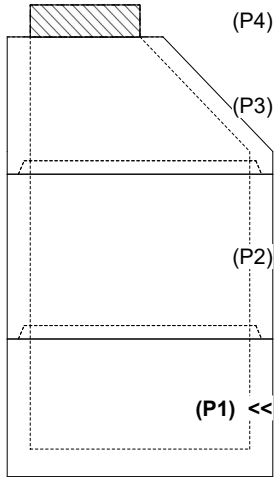

INSIDE WALL DIMENSIONS

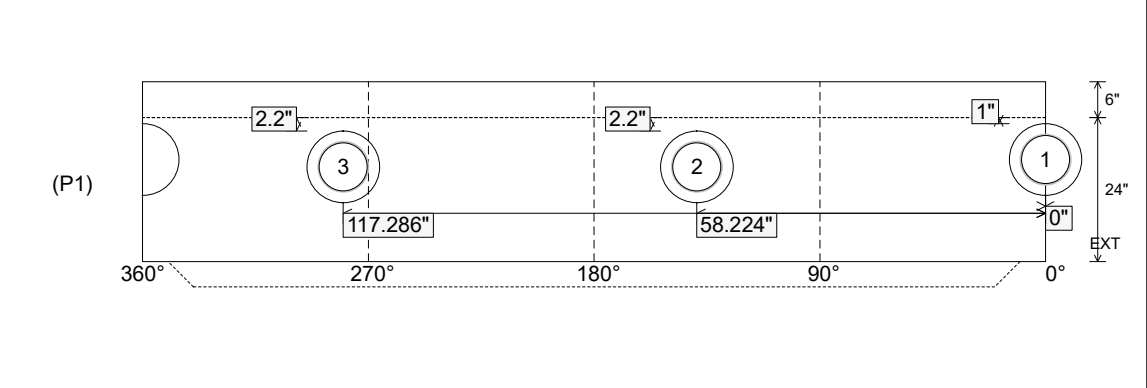

Coating (Int): Coating (Ext):	Seam Up: Tongue Seam Dn: n/a	Wall Thickness: 5" Floor Height: 6"	Height (Int): 24" Height (Ext): 30"	Weight (Net): 2863 lb Volume (Net): 0.73cu.yd
----------------------------------	---------------------------------	--	--	--