

Job Name: 25-4403 - Old Heritage Subdivision Section 6
Job Location: Shelbyville, KY 40065
Contractor: Filcon Construction

PC: C. Goff
 TECH: J. Horsey - F
 Plant: 100



Structure ID: 298
 Spec: Sanitary
 Type: SAN.MH
 Size: 48"

Rim: 782.64'
 Invert: 778'
 Rim to Invert: 4.64'

Sump: 3"
 Floor (Top): 777.75'
 Floor Height: 6"

Floor (Bot): 777.25'
 Overall Height: 5.333'
 Slack: 0.68"

Structure Notes:

1. PER ASTM C-478 SPECIFICATIONS
2. CONCRETE: 4,000 PSI AT 28 DAYS
3. REINFORCEMENT: PER ASTM A615
4. INVERT CHANNEL REQUIRED
5. STEPS AT 0 DEGREES
6. CASTING SUPPLIED BY OTHERS

STRUCTURE SUMMARY:

- P4) 24" - CASTING HEIGHT - 7" 0 lb
 - P3) 24" - GRADE RING F/F - 3" 202 lb
 - P2) 48" - ECC CONE w/ 24" HOLE F/G - 24" 1550 lb
 - P1) 48" - MH BASE T/n - 24" 2911 lb
 - 1) JOINT WRAP - 0.065"x6"x50' CONSEAL CS212 0 lb
 - 1) JOINT WRAP PRIMER - CONSEAL CS-75 (1 gal.) 0 lb
 - 1) 48" - MH INVERT CHANNEL - FULL HEIGHT 1440 lb
 - 1) 48" - Conseal CS-102 1.00" (Double) 0 lb
 - 1) PSX - 12-08 NYLO 8 lb
 - 1) PSX - 12-06 NYLO 8 lb
 - 3) MH Step ML-10-TDS-NCR - 10" 0 lb
- Structure Total: 6120 lb

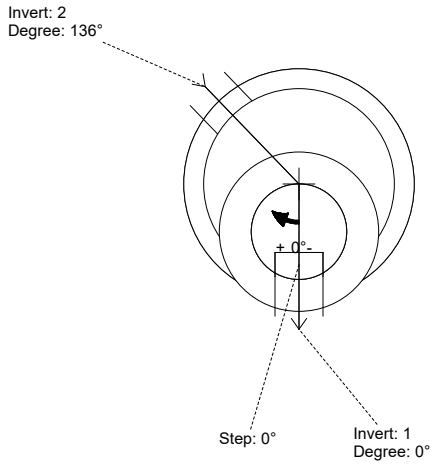

Position	Elev	Angle	Pipe	Pipe OD	Hole	Connector	Up (L)	Ref
Rim	782.64'							
Reducer								
Invert 1	778'	0°	8" PVC SDR35	8.5"	12"	PSX 12-08 NYLO	1"	P1
Invert 2	778.5'	136°	6" PVC SDR35	6.25"	12"	PSX 12-06 NYLO	6"	P1
Invert 3								
Invert 4								
Invert 5								
Invert 6								
Invert 7								
Invert 8								

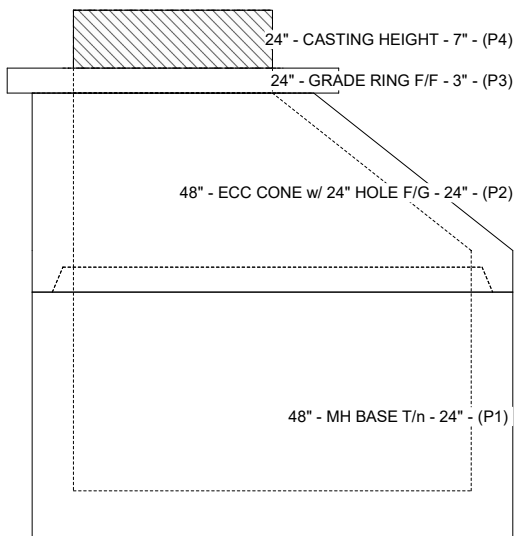

Cast (Int. Dim.) - Interior Dimensions

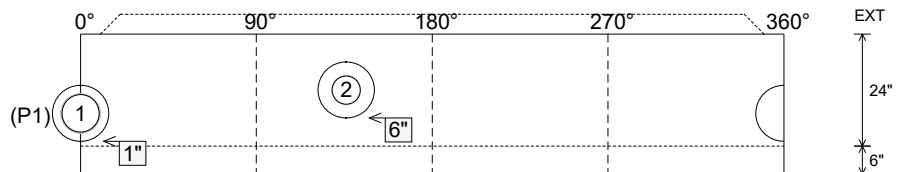

Submittal Drawing
 1/2/2026 1:20:15 PM

SUBMITTAL
 APPROVED BY: