

Job Name: 25-4403 - Old Heritage Subdivision Section 6  
 Job Location: Shelbyville, KY 40065  
 Contractor: Filcon Construction

Plant: 100  
 1/3/2026 12:54:31 PM

Tech: J. Hortsey - F  
 PC: C. Goff



**Structure ID: 18+85.96 LN 9**

**P2 MH048LD07SP**

**MH FLAT TOP w/24"x44" Hole F/F**

P3) 24" x 44" - CASTING HEIGHT - 3.50"  
 P2) 48" - MH FLAT TOP w/24"x44" Hole F/F - 7"  
 P1) 48" - MH BASE Custom Ht F/n - 23"  
 1) 48" - Conseal CS-102 1.00"  
 1) Hole - 20

0 lb  
 932 lb  
 2802 lb  
 0 lb  
 0 lb  
 -----  
 Structure Total: 3733 lb

**Structure Notes:**  
 1. PER ASTM C-478 SPECIFICATIONS  
 2. CONCRETE: 4,000 PSI AT 28 DAYS  
 3. REINFORCEMENT: #4 BAR @ 10" C.C. E.W. (GRADE 60) - 2" MIN. REBAR CLEARANCE (TYP)  
 4. NO INVERT CHANNEL  
 5. NO STEPS  
 6. CASTING SUPPLIED BY OTHERS  
 7. LIFTERS: 4 EA. WRA016 CONAC WIRE ROPE ANCHORS FOR PLANT & FIELD HANDLING

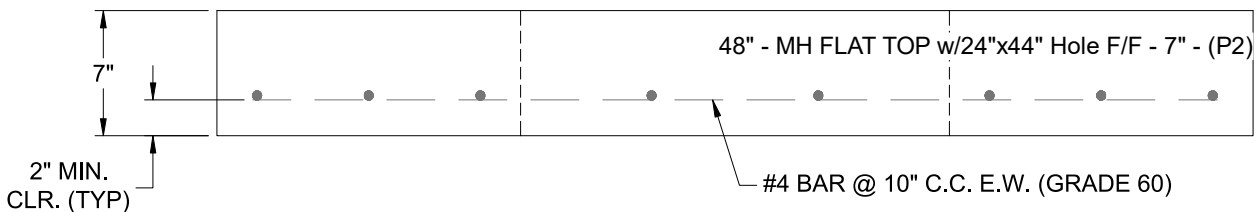
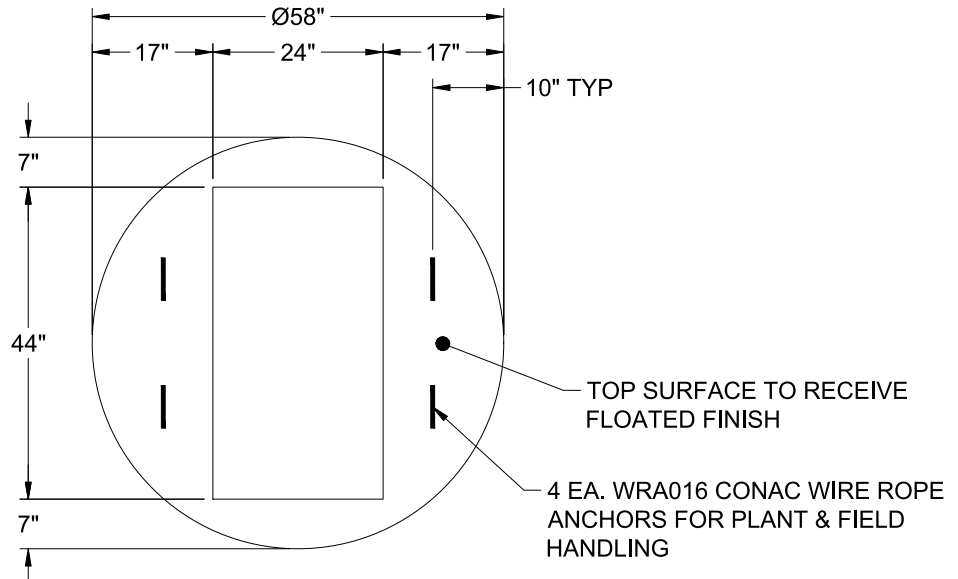

Coating (Int): Coating (Ext):	Seam Up: Flat Seam Dn: Flat	Wall Thickness: 5"	Height (Ext): 7"	Weight (Net): 932 lb Volume (Net): 0.24cu.yd
----------------------------------	--------------------------------	--------------------	------------------	---