

Job Name: 25-4403 - Old Heritage Subdivision Section 6
 Job Location: Shelbyville, KY 40065
 Contractor: Filcon Construction

Plant: 100
 1/3/2026 12:54:26 PM

Tech: J. Hortsey - F
 PC: C. Goff



Structure ID: 12+06.83 LN 10

P2 MH048LD12S

MH FLAT TOP w/24"x44" Hole F/G

- P3) 24" x 44" - CASTING HEIGHT - 3.50"
- P2) 48" - MH FLAT TOP w/24"x44" Hole F/G - 12"
- P1) 48" - MH BASE Custom Ht T/n - 35"
- 1) 48" - Conseal CS-102 1.00"
- 2) Hole - 16
- 3) MH Step ML-10-TDS-NCR - 10"

0 lb
 1187 lb
 3604 lb
 0 lb
 0 lb
 0 lb
 0 lb
 Structure Total: 4791 lb

- Structure Notes:**
1. PER ASTM C-478 SPECIFICATIONS
 2. CONCRETE: 4,000 PSI AT 28 DAYS
 3. REINFORCEMENT: #4 BAR @ 10" C.C. E.W. (GRADE 60) - 2" MIN. REBAR CLEARANCE (TYP)
 4. NO INVERT CHANNEL
 5. STEPS AT 125 DEGREES
 6. CASTING SUPPLIED BY OTHERS
 7. LIFTERS: 4 EA. WRA016 CONAC WIRE ROPE ANCHORS FOR PLANT & FIELD HANDLING

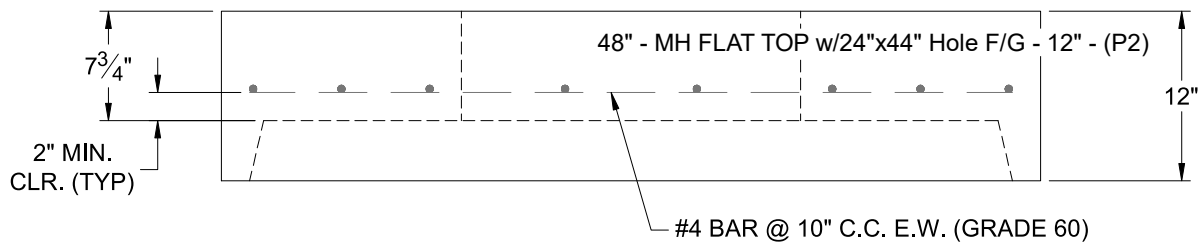
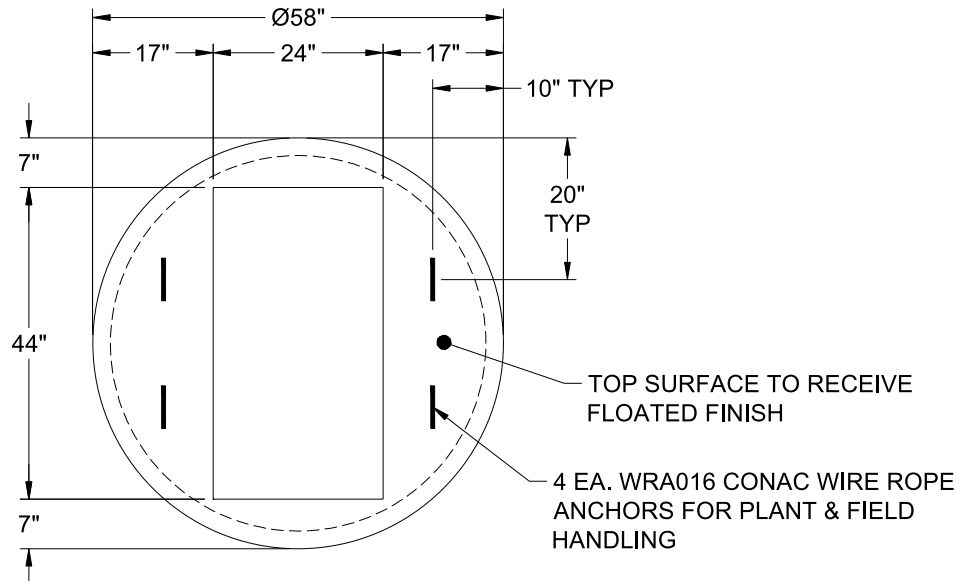

Coating (Int): Coating (Ext):	Seam Up: Flat Seam Dn: Groove	Wall Thickness: 5"	Height (Ext): 12"	Weight (Net): 1187 lb Volume (Net): 0.3cu.yd
----------------------------------	----------------------------------	--------------------	-------------------	---