

Structure ID: 12+06.83 LN 10

P1 MH048BAVF

MH BASE Custom Ht T/n

P3) 24" x 44" - CASTING HEIGHT - 3.50" P2) 48" - MH FLAT TOP w/24"x44" Hole F/G - 12" P1) 48" - MH BASE Custom Ht T/n - 35" 1) 48" - Conseal CS-102 1.00" 2) Hole - 16 3) MH Step ML-10-TDS-NCR - 10"	0 lb 1187 lb 3604 lb 0 lb 0 lb 0 lb ----- 4791 lb	Structure Notes: 1. PER ASTM C-478 SPECIFICATIONS 2. CONCRETE: 4,000 PSI AT 28 DAYS 3. REINFORCEMENT: PER ASTM A615 4. NO INVERT CHANNEL 5. STEPS AT 125 DEGREES 6. CASTING SUPPLIED BY OTHERS
----------------------------------------------------------------------------------------------------------------------------------------------------------------------------------------------------------------------	------------------------------------------------------------------------	-------------------------------------------------------------------------------------------------------------------------------------------------------------------------------------------------------------------------

Structure Total: 4791 lb

Rim: 773.22' Rim to Invert: 4.22' Slack: 0.14" Sump: 0" Step Position: 125°

Position	Elev	Angle	Ext. (cw)	Pipe	Pipe OD	Connector	Hole	Horz Size	Up ()	Offset
Invert 1	769'	0°	0"	12" HDPE	14.5"	Hole 16	16"	16.312"	-1.25"	0"
Invert 2	769'	250°	126.536"	12" HDPE	14.5"	Hole 16	16"	16.312"	-1.25"	0"
Invert 3										
Invert 4										
Invert 5										
Invert 6										
Invert 7										
Invert 8										

RIGHT-SIDE UP VIEW (int. dimensions)

UPSIDE-DOWN VIEW (int. dimensions)

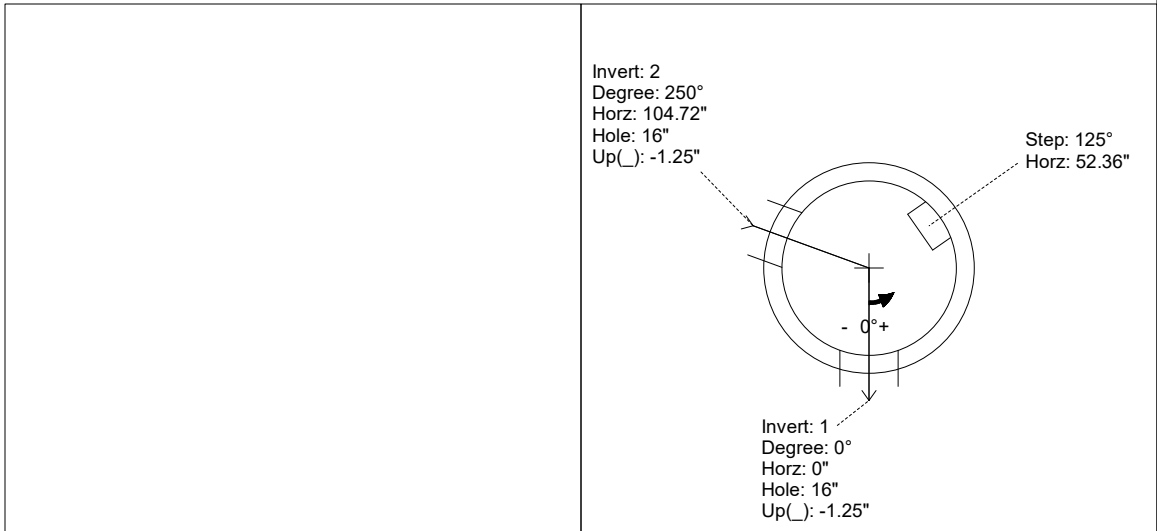
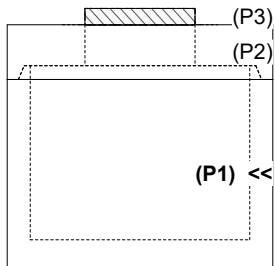

INSIDE WALL DIMENSIONS

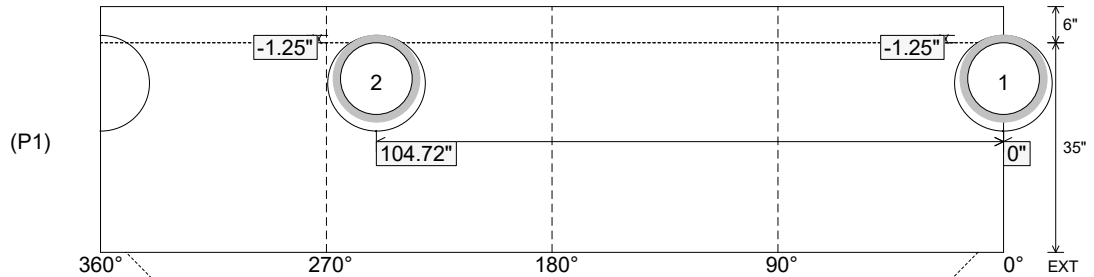

Coating (Int): Coating (Ext):	Seam Up: Tongue Seam Dn: n/a	Wall Thickness: 5" Floor Height: 6"	Height (Int): 35" Height (Ext): 41"	Weight (Net): 3604 lb Volume (Net): 0.92cu.yd
----------------------------------	---------------------------------	----------------------------------------	----------------------------------------	--------------------------------------------------