

Structure ID: 11+58.00 LN 9

P1 MH060BAVF

MH BASE Custom Ht T/n

P3) 24" x 44" - CASTING HEIGHT - 3.50" P2) 60" - MH FLAT TOP w/24"x44" Hole F/G - 13" P1) 60" - MH BASE Custom Ht T/n - 51" 1) 60" - Conseal CS-102 1.00" 1) Hole - 44 1) Hole - 30 4) MH Step ML-10-TDS-NCR - 10"	0 lb 2347 lb 6846 lb 0 lb 0 lb 0 lb 0 lb 0 lb 9193 lb	Structure Notes: 1. PER ASTM C-478 SPECIFICATIONS 2. CONCRETE: 4,000 PSI AT 28 DAYS 3. REINFORCEMENT: PER ASTM A615 4. NO INVERT CHANNEL 5. STEPS AT 125 DEGREES 6. CASTING SUPPLIED BY OTHERS
--	---	---

Structure Total: 9193 lb

Rim: 781.84' Rim to Invert: 5.46' Slack: 0.87" Sump: 2.85" Step Position: 125°

Position	Elev	Angle	Ext. (cw)	Pipe	Pipe OD	Connector	Hole	Horz Size	Up ()	Offset
Invert 1	776.38'	0°	0"	36" HDPE	41.7"	Hole 44	44"	49.393"	0"	0"
Invert 2	776.38'	254°	159.593"	24" HDPE	27.8"	Hole 30	30"	31.416"	0.95"	0"
Invert 3										
Invert 4										
Invert 5										
Invert 6										
Invert 7										
Invert 8										

RIGHT-SIDE UP VIEW (int. dimensions)

UPSIDE-DOWN VIEW (int. dimenions)

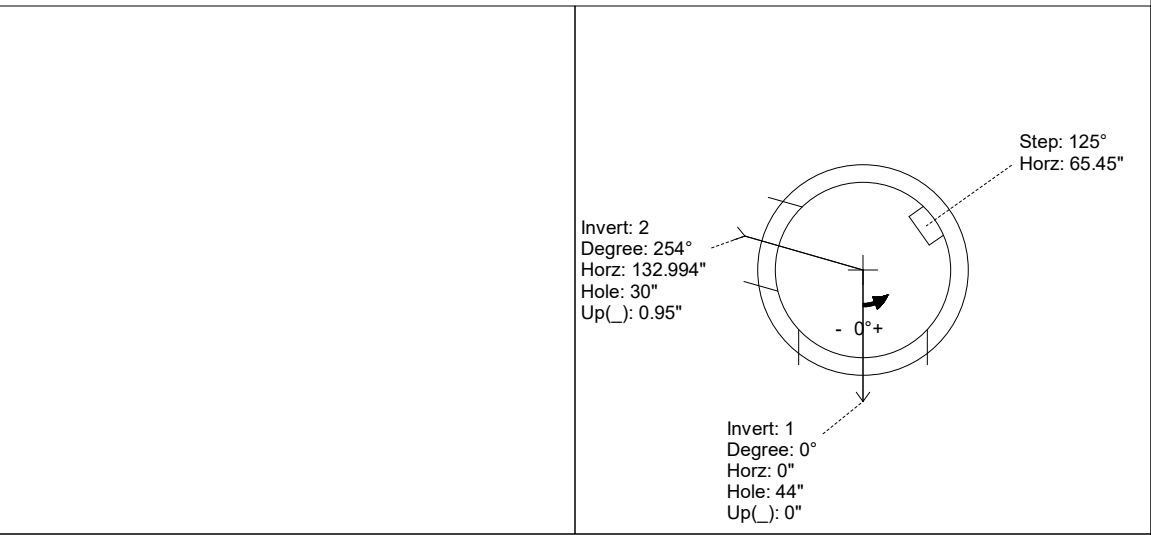
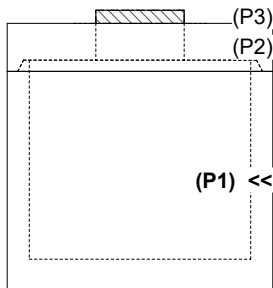

INSIDE WALL DIMENSIONS

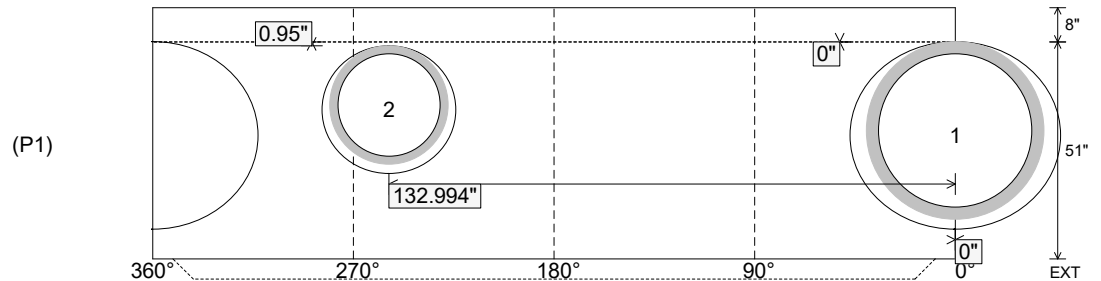

Coating (Int): Coating (Ext):	Seam Up: Tongue Seam Dn: n/a	Wall Thickness: 6" Floor Height: 8"	Height (Int): 51" Height (Ext): 59"	Weight (Net): 6846 lb Volume (Net): 1.75cu.yd
----------------------------------	---------------------------------	--	--	--