

**Structure ID: 202**

**P2 MH072RSVF**

**MH RISER Custom Ht**

- P3) 72" - CASTING HEIGHT - 4"
- P2) 72" - MH RISER Custom Ht - 80"
- P1) 72" - MH BASE Custom Ht - 36"
- 2) 72" - Conseal CS-102 1.00"
- 1) Hole - 40
- 1) Hole - 26
- 1) SQ. Hole - 48"x22"

0 lb  
 9901 lb  
 9148 lb  
 0 lb  
 0 lb  
 0 lb  
 0 lb  
 -----  
 19048 lb

Structure Total:

Structure Notes:

1. JR HOE MC-295 BY ICAST.
2. BMP SNOOT 52RTB/72 W/ KIT BY ICAST.
3. PER ASTM C478 SPECIFICATIONS.
4. CONCRETE = 4,000 PSI AT 28 DAYS.
5. REINFORCING PER ASTM A615 (GRADE 60).
  - TOP SLAB (As .62) #5 BARS AT 6" C.C.E.W..
  - RISER/WALLS (As .18)
  - FLOOR (As .37) #5 BARS AT 10" C.C.E.W.
6. NO TOP SLAB (TO USE STEEL PLATE PROVIDED BY OTHERS)
7. 48" X 22" OPENING FOR 2X 18" STEEL PIPES.

Rim: 384.61'    Rim to Invert: 3.79'    Slack: 0.48"    Sump: 75"    Step Position:

| Position | Elev    | Angle | Ext. (cw) | Pipe           | Pipe OD | Connector        | Hole      | Horz Size | Up ( )  | Offset |
|----------|---------|-------|-----------|----------------|---------|------------------|-----------|-----------|---------|--------|
| Invert 1 | 380.82' | 0°    | 0"        | 30" RCP B WALL | 37"     | Hole 40          | 40"       | 42.41"    | 30.5"   | 0"     |
| Invert 2 | 381.75' | 60°   | 45.029"   | 18" RCP B WALL | 23"     | Hole 26          | 26"       | 26.601"   | 42.66"  | 0"     |
| Invert 3 | 382.45' | 140°  | 105.069"  | 18" Steel      | 18"     | SQ. Hole 48"x22" | 48" x 22" | 52.54"    | 52.985" | 0"     |
| Invert 4 |         |       |           |                |         |                  |           |           |         |        |
| Invert 5 |         |       |           |                |         |                  |           |           |         |        |
| Invert 6 |         |       |           |                |         |                  |           |           |         |        |
| Invert 7 |         |       |           |                |         |                  |           |           |         |        |
| Invert 8 |         |       |           |                |         |                  |           |           |         |        |

**RIGHT-SIDE UP VIEW (int. dimensions)**

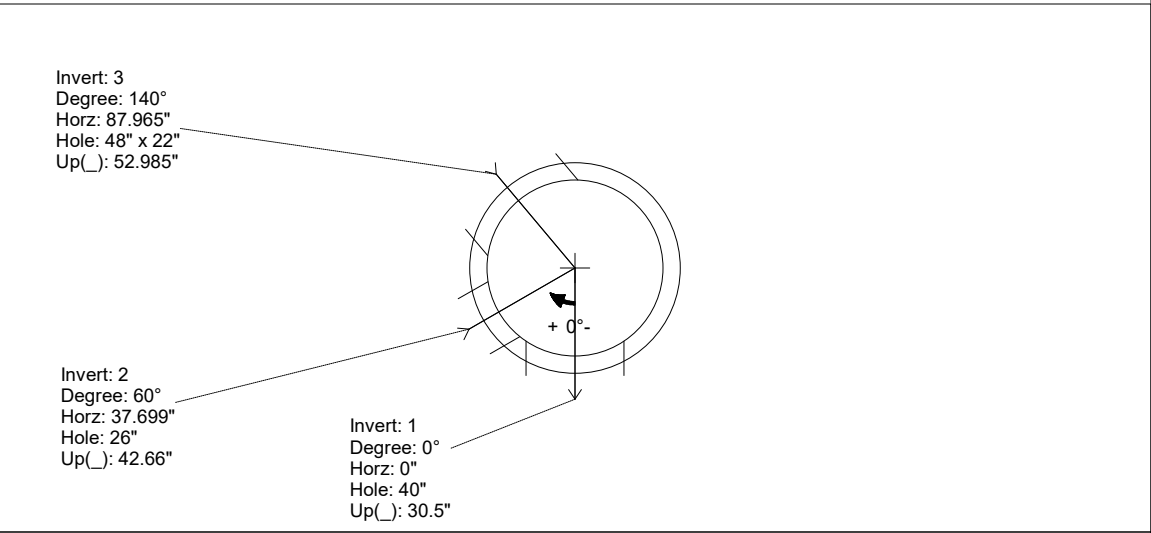
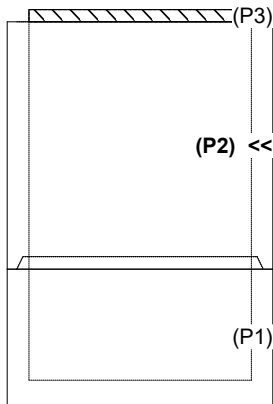

**INSIDE WALL DIMENSIONS**

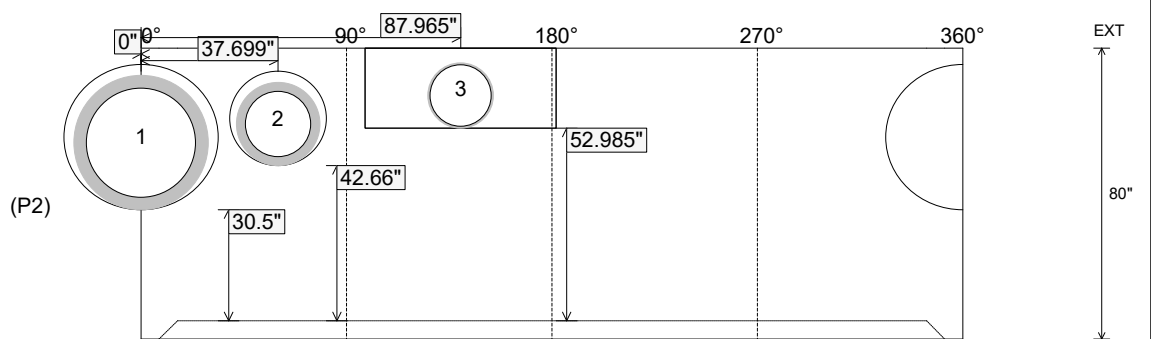

|                                  |                                  |  |  |  |
|----------------------------------|----------------------------------|--|--|--|
| Coating (Int):<br>Coating (Ext): | Seam Up: Flat<br>Seam Dn: Groove | Wall Thickness: 7"<br>Floor Height: 0" | Height (Int): 80"<br>Height (Ext): 80" | Weight (Net): 9901 lb<br>Volume (Net): 2.53cu.yd |
|----------------------------------|----------------------------------|--|--|--|