

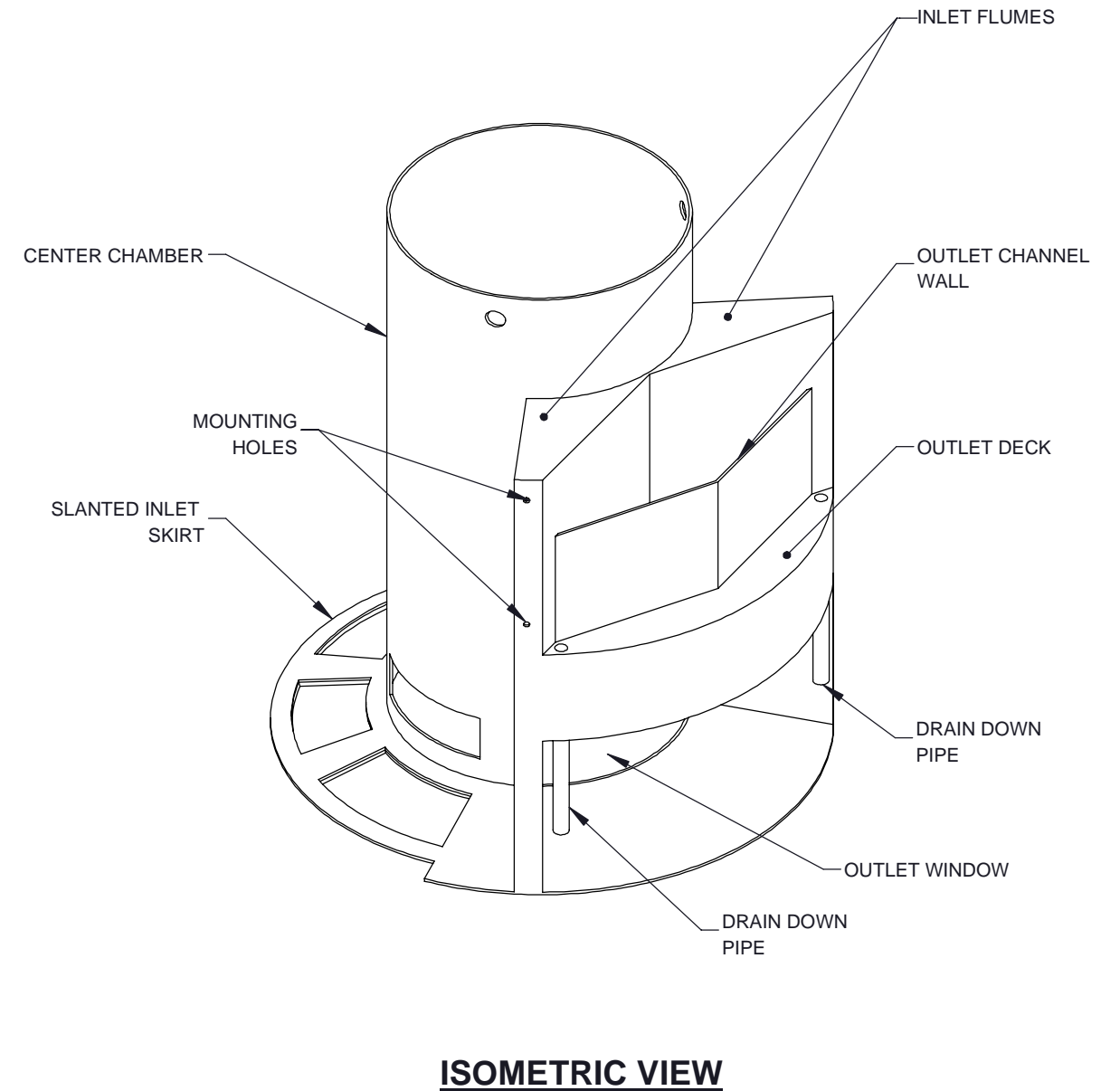

# 25-4381 - 815186 EVERGY RAYTOWN SUBSTATION

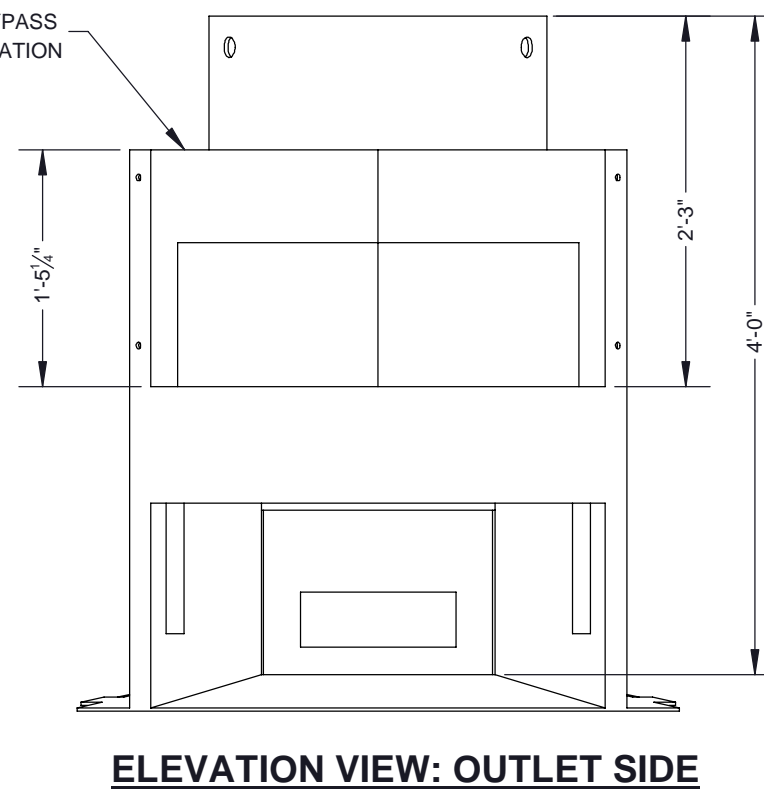
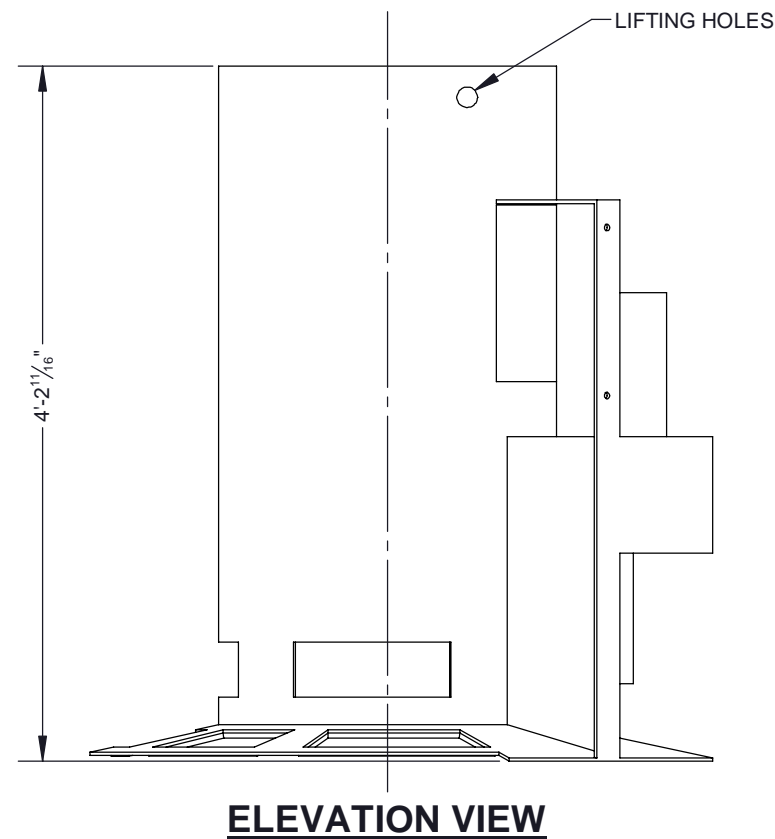
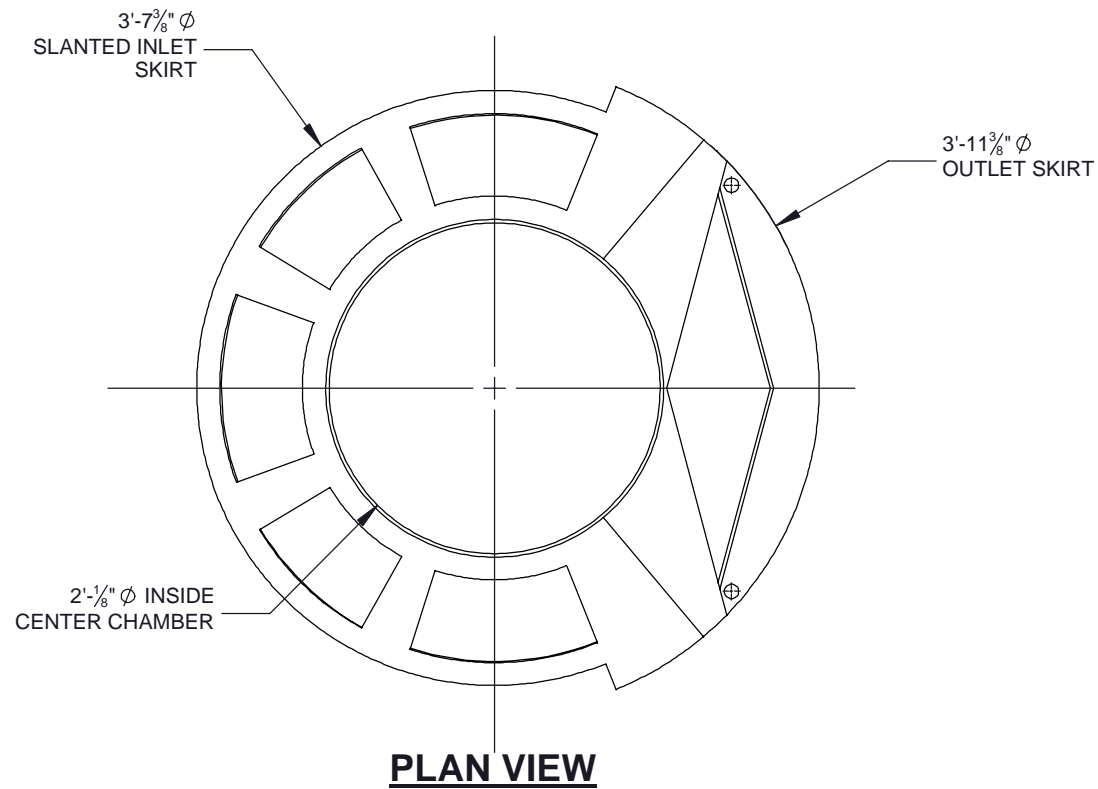

- NOTES:  
1. SEE CASCADE SEPARATOR INSTALLATION GUIDE FOR ADDITIONAL INFORMATION

The design and information shown on this drawing is provided as a service to the project owner, engineer and contractor by Contech Engineered Solutions LLC, or one of its affiliated companies ("Contech"). Neither this drawing, nor any part thereof, may be used, reproduced or modified in any manner without the prior written consent of Contech. Failure to comply is done at the user's own risk and Contech expressly disclaims any liability or responsibility for such use.

If discrepancies between the supplied information upon which the drawing is based and actual field conditions are encountered as site work progresses, these discrepancies must be reported to Contech immediately for re-evaluation of the design. Contech accepts no liability for designs based on missing, incomplete or inaccurate information supplied by others.

## CASCADE separator™

**CONTECH**  
ENGINEERED SOLUTIONS LLC

www.ContechES.com  
9025 Centre Pointe Dr., Suite 400, West Chester, OH 45069  
800-338-1122 513-645-7000 513-645-7993 FAX

REFERENCE DETAIL  
INTERNALS CS-4  
CASCADE SEPARATOR

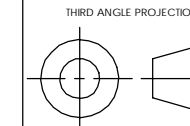

UNLESS OTHERWISE SPECIFIED  
DIMENSIONS ARE IN INCHES

TOLERANCES:  
FRACTIONAL ± 1/16  
ANGLES ± 1 DEGREE  
TWO PLACE DECIMAL ± 0.06  
THREE PLACE DECIMAL ± 0.030

PART NUMBER: 325-003949		
APPROVED BY: M. BROOKS	DRAWN BY: M. BROOKS	
APPROVED BY DATE: 2021.10.21	DRAWN BY DATE: 2021.09.14	REV: B
SCALE: N/A	SHEET 1 OF 1	