

Job Name: 25-4342 Pebble Wood Gravity Tie In  
 Job Location: Owensboro, Kentucky  
 Contractor: Ernie Davis & Sons Mechanical, Inc.

Plant: Beaver Dam  
 2/2/2026 1:43:34 PM

Tech: S. Felletter  
 PC: A. Chambers



**Structure ID: A2**

**P3 MH048CN36CDARED**

**ECC CONE w/ 24" HOLE, w/ConBlock-CDA Red F/G**

P5) 24" - CASTING HEIGHT - 7"	0 lb
P4) 24" - GRADE RING w/ConBlock-CDA Red F/F - 4"	270 lb
P3) 48" - ECC CONE w/ 24" HOLE, w/ConBlock-CDA Red F/G - 36"	2251 lb
P2) 48" - MH RISER w/ConBlock-CDA Red T/G - 60"	4192 lb
P1) 48" - MH BASE w/ConBlock-CDA Red T/n - 30"	3282 lb
1) JOINT WRAP - 0.065"x6"x50' CONSEAL CS212	0 lb
1) JOINT WRAP PRIMER - CONSEAL CS-75 (1 gal.)	0 lb
1) 48" - MH INVERT CHANNEL w/ConBlock-CDA Red - FULL HEIGHT	1440 lb
2) 48" - Conseal CS-102 1.00" (Double)	0 lb
1) PSX - 12M NYLO	8 lb
2) PSX - 12-08 NYLO	16 lb
10) MH Step ML-10-TDS-NCR - 10"	0 lb
Structure Total:	11459 lb

Structure Notes:  
 1. (7" TALL CASTING PROVIDED BY OTHERS)  
 1. PER ASTM C478 SPECIFICATIONS.  
 2. CONCRETE = 4,000 PSI AT 28 DAYS.  
 3. ADMIXTURE = CONBLOCK CDA RED.

REINFORCING PER ASTM A615 (GRADE 60).  
 - CONE (As .12)  
 - RISER/WALLS (As .12)  
 - FLOOR (As .31) #5 BARS AT 12" C.C.E.W.

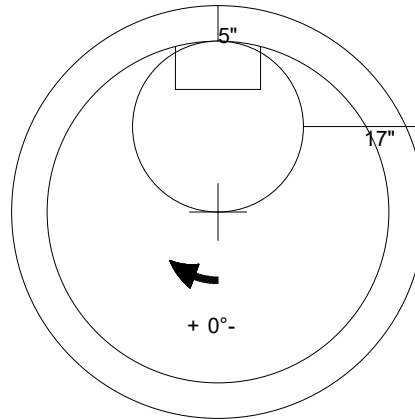

48" - ECC CONE w/ 24" HOLE, w/ConBlock-CDA Red F/G - 36" - (P3)

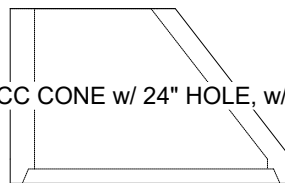

Coating (Int): Coating (Ext):	Seam Up: Flat Seam Dn: Groove	Wall Thickness: 5"	Height (Ext): 36"	Weight (Net): 2251 lb Volume (Net): 0.57cu.yd
----------------------------------	----------------------------------	--------------------	-------------------	--