

Job Name: 25-4337 - Maywood Phase13 Job Location: Bardstown, KY Contractor: Buzick Construction	Plant: 100	Tech: J. Horsley - F	
	12/9/2025 11:21:38 AM	PC: C. Goff	

Structure ID: CI9

P1 BX2436-08BVF

BOX BASE 8inW, 8inF, Variable Ht F/n

- P2) 24" x 36" - CASTING HEIGHT - 6"
- P1) 24" x 36" - BOX BASE 8inW, 8inF, Variable Ht F/n - 34"
- 1) 24" x 36" - Conseal CS-102 1.00"
- 1) Hole - 24
- 1) Hole - 26

0 lb
4163 lb
0 lb
0 lb
0 lb

Structure Total: 4163 lb

- Structure Notes:
1. PER ASTM C-913 SPECIFICATIONS
 2. CONCRETE: 4,000 PSI AT 28 DAYS
 3. REINFORCEMENT: #5 BAR @ 12" C.C. E.W. (GRADE 60) - 2" MIN. REBAR CLEARANCE (TYP)
 4. NO STEPS AND NO INVERT CHANNEL
 5. CASTING SUPPLIED BY OTHERS (HOE 470 FRAME, GRATE, & CURB HOOD)

Rim: 702.05' Rim to Invert: 3.37' Slack: 0.44" Sump: 0" Step Position:

Position	Elev	Angle	Ext. (cw)	Pipe	Pipe OD	Connector	Hole	Horz Size	Up ()	Offset
Invert 1	698.68'	70°	24.041"	18" HDPE	21.2"	Hole 24	24"	25.54"	-1.6"	5"
Invert 2	698.68'	250°	24.041"	18" RCP B WALL	23"	Hole 26	26"	27.669"	-2.5"	5"
Invert 3										
Invert 4										
Invert 5										
Invert 6										
Invert 7										
Invert 8										

RIGHT-SIDE UP VIEW (int. dimensions)

UPSIDE-DOWN VIEW (int. dimenions)

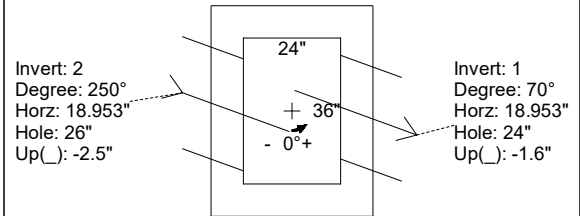
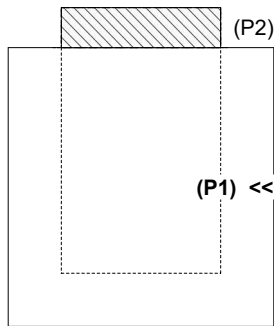

INSIDE WALL DIMENSIONS

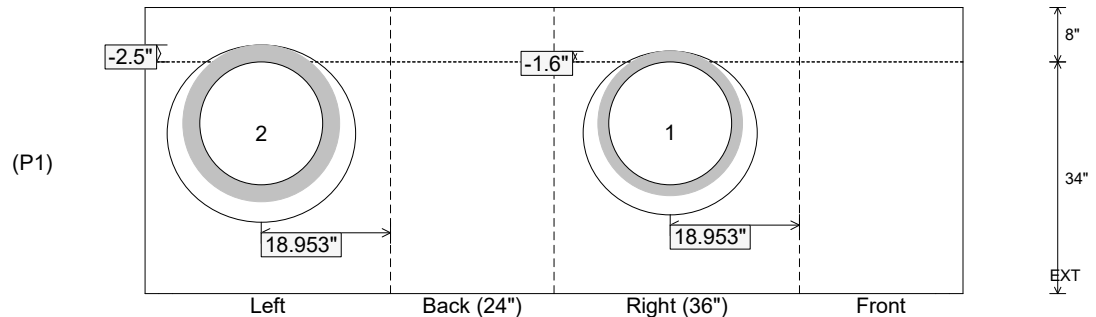

Coating (Int): Coating (Ext):	Seam Up: Flat Seam Dn: n/a	Wall Thickness: 8" Floor Height: 8"	Height (Int): 34" Height (Ext): 42"	Weight (Net): 4163 lb Volume (Net): 1.06cu.yd
----------------------------------	-------------------------------	--	--	--