

Job Name: 25-4337 - Maywood Phase13
 Job Location: Bardstown, KY
 Contractor: Buzick Construction

Plant: 100

Tech: J. Horsley - F

12/9/2025 11:29:34 AM

PC: C. Goff



Structure ID: C18

P2 MH060LD08-24X36RECT

MH FLAT TOP w/24"x36" Hole F/F

- P3) 24" x 36" - CASTING HEIGHT - 6"
- P2) 60" - MH FLAT TOP w/24"x36" Hole F/F - 8"
- P1) 60" - MH BASE Custom Ht F/n - 56"
- 1) 60" - Conseal CS-102 1.00"
- 1) 24" x 36" - Conseal CS-102 1.00"
- 1) Hole - 44
- 1) Hole - 48
- 4) MH Step ML-10-TDS-NCR - 10"

0 lb
 2153 lb
 6711 lb
 0 lb
 0 lb
 0 lb
 0 lb
 0 lb
 0 lb

 8864 lb

Structure Total:

Structure Notes:

1. PER ASTM C-478 SPECIFICATIONS
2. CONCRETE: 4,000 PSI AT 28 DAYS
3. REINFORCEMENT: #5 BAR @ 6" C.C. E.W. (GRADE 60) - 2" MIN. REBAR CLEARANCE (TYP)
4. NO INVERT CHANNEL
5. CASTING SUPPLIED BY OTHERS (HOE 470 FRAME, GRATE, & CURB HOOD)
6. LIFTERS: 4 EA. WRA016 CONAC WIRE ROPE ANCHORS FOR PLANT & FIELD HANDLING

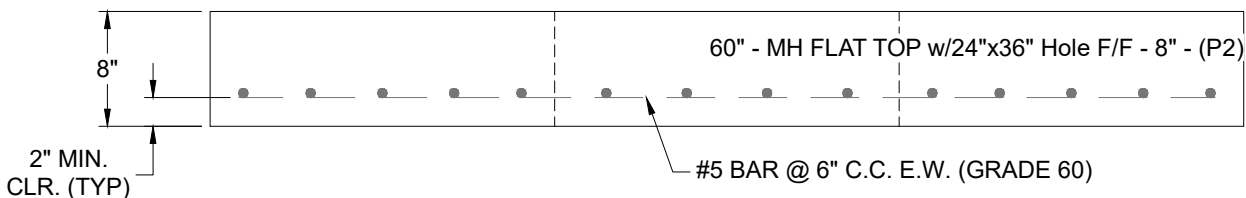
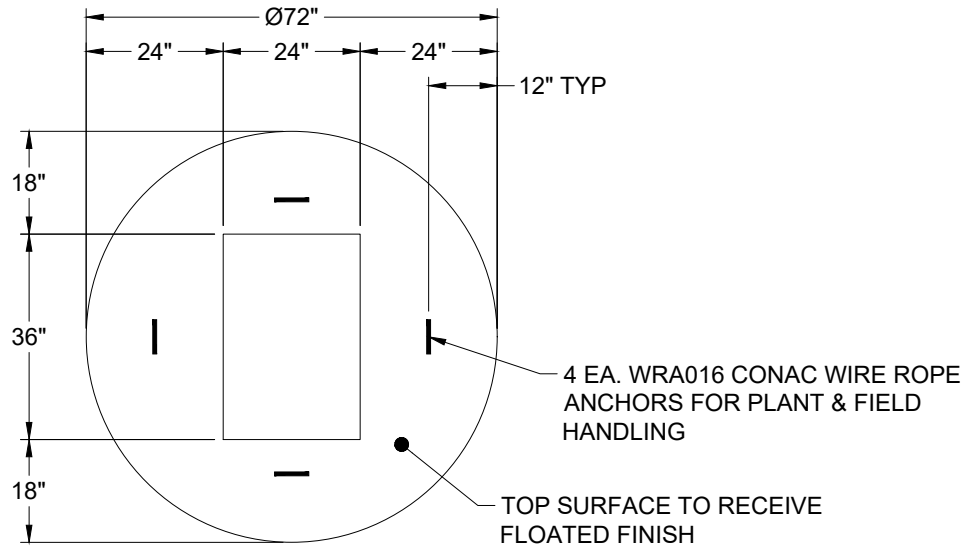

Coating (Int):
 Coating (Ext):

Seam Up: Flat
 Seam Dn: Flat

Wall Thickness: 6"

Height (Ext): 8"

Weight (Net): 2153 lb
 Volume (Net): 0.55cu.yd