

Job Name: 25-4337 - Maywood Phase13
 Job Location: Bardstown, KY
 Contractor: Buzick Construction

Plant: 100

12/9/2025 11:29:33 AM

Tech: J. Horsley - F

PC: C. Goff



Structure ID: CB9

P2 MH048LD12S

MH FLAT TOP w/32"x32" Hole F/G

- P3) 32" x 32" - CASTING HEIGHT - 3"
- P2) 48" - MH FLAT TOP w/32"x32" Hole F/G - 12"
- P1) 48" - MH BASE Custom Ht T/n - 38"
- 1) 48" - Conseal CS-102 1.00"
- 1) 32" x 32" - Conseal CS-102 1.00"
- 1) Hole - 30
- 2) Hole - 24

- 0 lb
- 1629 lb
- 3274 lb
- 0 lb
- 0 lb
- 0 lb
- 0 lb
- 0 lb

Structure Total: 4904 lb

- Structure Notes:**
1. PER ASTM C-478 SPECIFICATIONS
 2. CONCRETE: 4,000 PSI AT 28 DAYS
 3. REINFORCEMENT: #4 BAR @ 10" C.C. E.W. (GRADE 60) - 2" MIN. REBAR CLEARANCE (TYP)
 4. NO STEPS AND NO INVERT CHANNEL
 5. CASTING SUPPLIED BY OTHERS (HOE 595 FRAME & GRATE)
 6. LIFTERS: 4 EA. WRA016 CONAC WIRE ROPE ANCHORS FOR PLANT & FIELD HANDLING

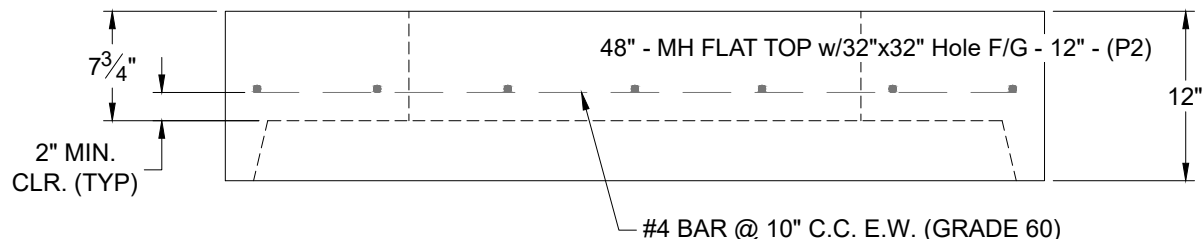
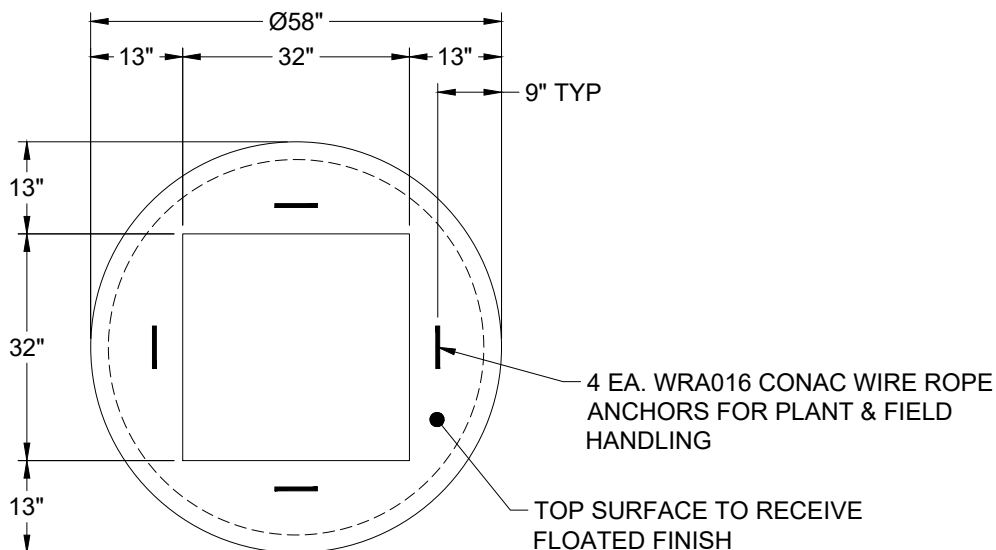

Coating (Int):
 Coating (Ext):

Seam Up: Flat
 Seam Dn: Groove

Wall Thickness: 5"

Height (Ext): 12"

Weight (Net): 1629 lb
 Volume (Net): 0.42cu.yd