

**Structure ID: CB9**

**P1 MH048BAVF**

**MH BASE Custom Ht T/n**

P3) 32" x 32" - CASTING HEIGHT - 3" P2) 48" - MH FLAT TOP w/32"x32" Hole F/G - 12" P1) 48" - MH BASE Custom Ht T/n - 38" 1) 48" - Conseal CS-102 1.00" 1) 32" x 32" - Conseal CS-102 1.00" 1) Hole - 30 2) Hole - 24	0 lb 1629 lb 3274 lb 0 lb 0 lb 0 lb 0 lb 0 lb ----- 4904 lb Structure Total:
--	--

**Structure Notes:**

1. PER ASTM C-478 SPECIFICATIONS
2. CONCRETE: 4,000 PSI AT 28 DAYS
3. REINFORCEMENT: PER ASTM A615
4. NO STEPS AND NO INVERT CHANNEL
5. CASTING SUPPLIED BY OTHERS (HOE 595 FRAME & GRATE)

Rim: 702.57'    Rim to Invert: 4.26'    Slack: 0.02"    Sump: 1.9"    Step Position:

Position	Elev	Angle	Ext. (cw)	Pipe	Pipe OD	Connector	Hole	Horz Size	Up ( )	Offset
Invert 1	698.31'	0°	0"	24" HDPE	27.8"	Hole 30	30"	32.406"	0"	0"
Invert 2	698.31'	115°	58.207"	18" HDPE	21.2"	Hole 24	24"	25.133"	0.3"	0"
Invert 3	698.31'	218°	110.34"	18" HDPE	21.2"	Hole 24	24"	25.133"	0.3"	0"
Invert 4										
Invert 5										
Invert 6										
Invert 7										
Invert 8										

RIGHT-SIDE UP VIEW (int. dimensions)

UPSIDE-DOWN VIEW (int. dimensions)

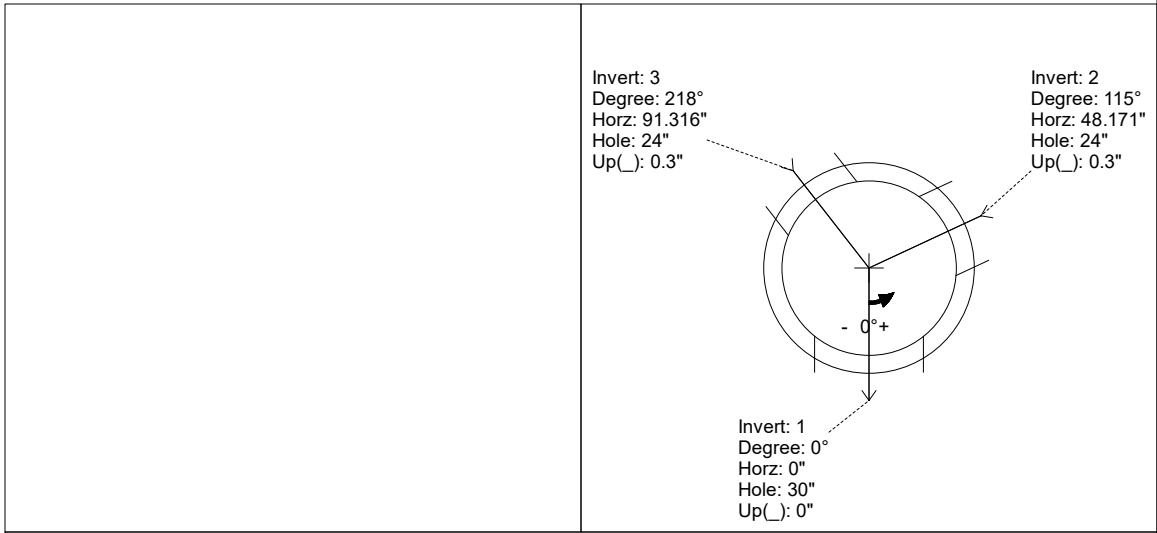
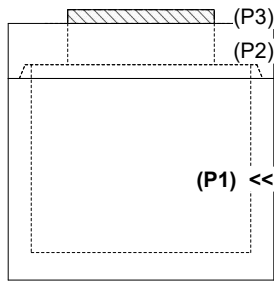

INSIDE WALL DIMENSIONS

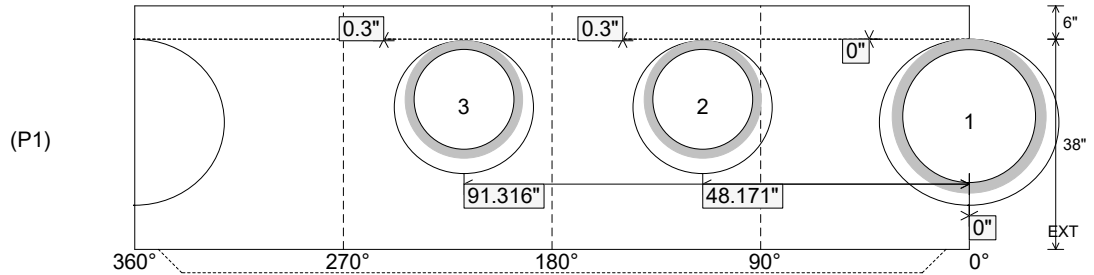

Coating (Int): Coating (Ext):	Seam Up: Tongue Seam Dn: n/a	Wall Thickness: 5" Floor Height: 6"	Height (Int): 38" Height (Ext): 44"	Weight (Net): 3274 lb Volume (Net): 0.84cu.yd
----------------------------------	---------------------------------	--	--	--