

Job Name: 25-4337 - Maywood Phase13 Job Location: Bardstown, KY Contractor: Buzick Construction	Plant: 100 12/9/2025 11:21:44 AM	Tech: J. Horsley - F PC: C. Goff	
---	-------------------------------------	-------------------------------------	--

Structure ID: CB12

P1 BX3636-08BAVF

BOX BASE 8inW, 8inF, Variable Ht F/n

- P2) 36" x 36" - CASTING HEIGHT - 3"
- P1) 36" x 36" - BOX BASE 8inW, 8inF, Variable Ht F/n - 39"
- 1) 36" x 36" - Conseal CS-102 1.00"
- 2) Hole - 24"

0 lb
5784 lb
0 lb
0 lb

Structure Total: 5784 lb

- Structure Notes:**
1. PER ASTM C-913 SPECIFICATIONS
 2. CONCRETE: 4,000 PSI AT 28 DAYS
 3. REINFORCEMENT: #5 BAR @ 12" C.C. E.W. (GRADE 60) - 2" MIN. REBAR CLEARANCE (TYP)
 4. NO STEPS AND NO INVERT CHANNEL
 5. CASTING SUPPLIED BY OTHERS (HOE 595 FRAME & GRATE)

Rim: 703' Rim to Invert: 3.56' Slack: 0.72" Sump: 0" Step Position:

Position	Elev	Angle	Ext. (cw)	Pipe	Pipe OD	Connector	Hole	Horz Size	Up ()	Offset
Invert 1	699.44'	335°	22.151"	18" HDPE	21.2"	Hole 24	24"	26.481"	-1.6"	7.5"
Invert 2	699.44'	90°	26"	18" HDPE	21.2"	Hole 24	24"	24"	-1.6"	0"
Invert 3										
Invert 4										
Invert 5										
Invert 6										
Invert 7										
Invert 8										

RIGHT-SIDE UP VIEW (int. dimensions)

UPSIDE-DOWN VIEW (int. dimensions)

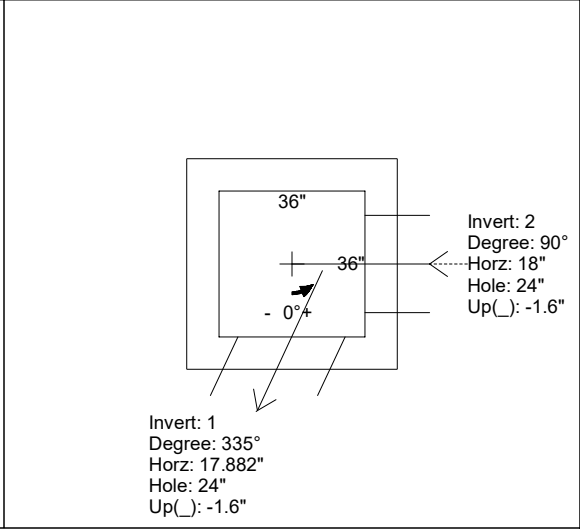
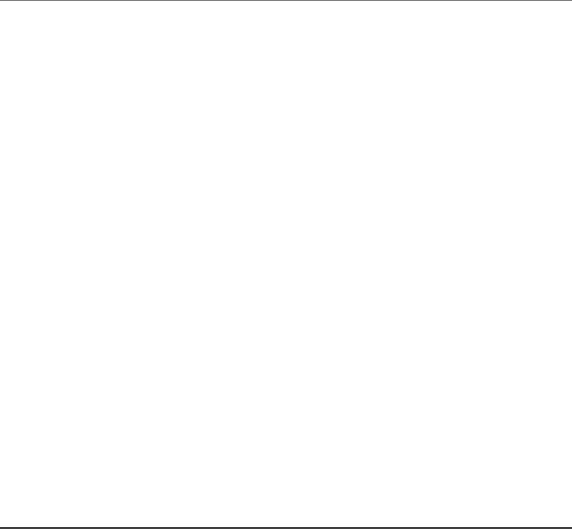
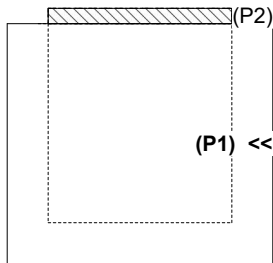

INSIDE WALL DIMENSIONS

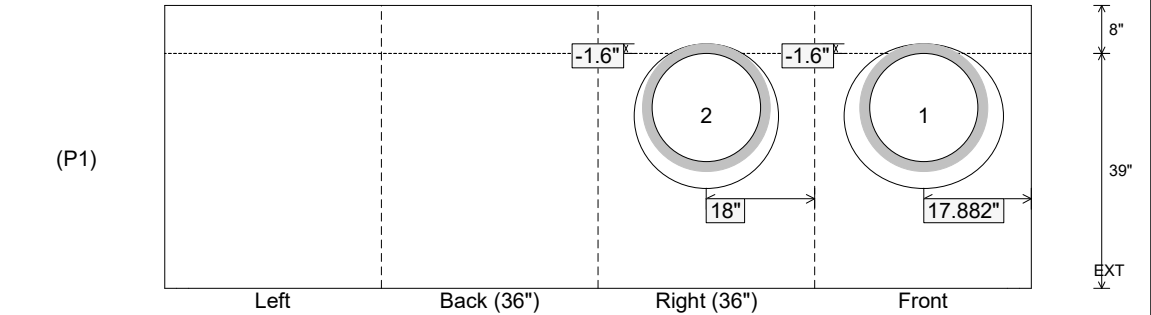

Coating (Int): Coating (Ext):	Seam Up: Flat Seam Dn: n/a	Wall Thickness: 8" Floor Height: 8"	Height (Int): 39" Height (Ext): 47"	Weight (Net): 5784 lb Volume (Net): 1.48cu.yd
----------------------------------	-------------------------------	--	--	--