

Job Name: 25-4337 - Maywood Phase13
 Job Location: Bardstown, KY
 Contractor: Buzick Construction

Plant: 100

12/9/2025 11:29:29 AM

Tech: J. Horsley - F

PC: C. Goff



Structure ID: C1

P3 MH048CN24

ECC CONE w/ 24" HOLE F/G

- P5) 24" - CASTING HEIGHT - 7"
- P4) 24" - GRADE RING F/F - 4"
- P3) 48" - ECC CONE w/ 24" HOLE F/G - 24"
- P2) 48" - MH RISER T/G - 36"
- P1) 48" - MH BASE T/n - 24"

- 1) JOINT WRAP - 0.065"x6"x50' CONSEAL CS212
- 1) JOINT WRAP PRIMER - CONSEAL CS-75 (1 gal.)
- 1) 48" - MH INVERT CHANNEL - FULL HEIGHT
- 2) 48" - Conseal CS-102 1.00" (Double)
- 2) PSX - 12-08 NYLO
- 1) PSX - 12-06 NYLO
- 6) MH Step ML-10-TDS-NCR - 10"

0 lb
 270 lb
 1550 lb
 2515 lb
 2863 lb
 0 lb
 0 lb
 1440 lb
 0 lb
 16 lb
 8 lb
 0 lb

Structure Total: 8662 lb

Structure Notes:

1. PER ASTM C-478 SPECIFICATIONS
2. CONCRETE: 4,000 PSI AT 28 DAYS
3. REINFORCEMENT: PER ASTM A615
4. CASTING SUPPLIED BY OTHERS (HOE MC-350 FRAME & COVER "SANITARY")

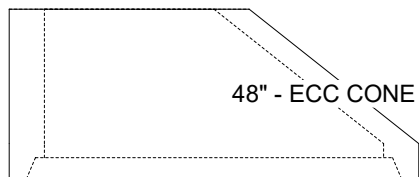
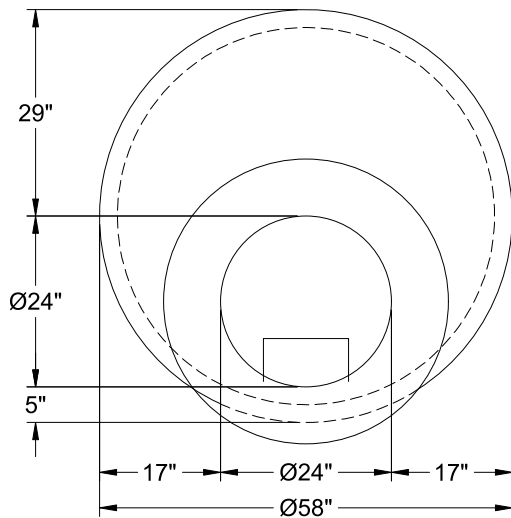

Coating (Int):
 Coating (Ext):

Seam Up: Flat
 Seam Dn: Groove

Wall Thickness: 5"

Height (Ext): 24"

Weight (Net): 1550 lb
 Volume (Net): 0.33cu.yd