

Job Name: 25-4337 - Maywood Phase13  
 Job Location: Bardstown, KY  
 Contractor: Buzick Construction

Plant: 100

Tech: J. Horsley - F

12/9/2025 11:29:27 AM

PC: C. Goff



**Structure ID: A11**

**P2 MH048CN24**

**ECC CONE w/ 24" HOLE F/G**

- P3) 24" - CASTING HEIGHT - 7"
- P2) 48" - ECC CONE w/ 24" HOLE F/G - 24"
- P1) 48" - MH BASE T/n - 30"

- 1) JOINT WRAP - 0.065"x6"x50' CONSEAL CS212
- 1) JOINT WRAP PRIMER - CONSEAL CS-75 (1 gal.)
- 1) 48" - MH INVERT CHANNEL - FULL HEIGHT
- 1) 48" - Conseal CS-102 1.00" (Double)
- 1) PSX - 12-08 NYLO
- 4) MH Step ML-10-TDS-NCR - 10"

0 lb  
 1550 lb  
 3378 lb  
 0 lb  
 0 lb  
 1440 lb  
 0 lb  
 8 lb  
 0 lb  
 -----  
 Structure Total: 6376 lb

Structure Notes:

1. PER ASTM C-478 SPECIFICATIONS
2. CONCRETE: 4,000 PSI AT 28 DAYS
3. REINFORCEMENT: PER ASTM A615
4. CASTING SUPPLIED BY OTHERS (HOE MC-350 FRAME & COVER "SANITARY")

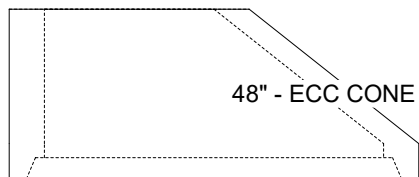
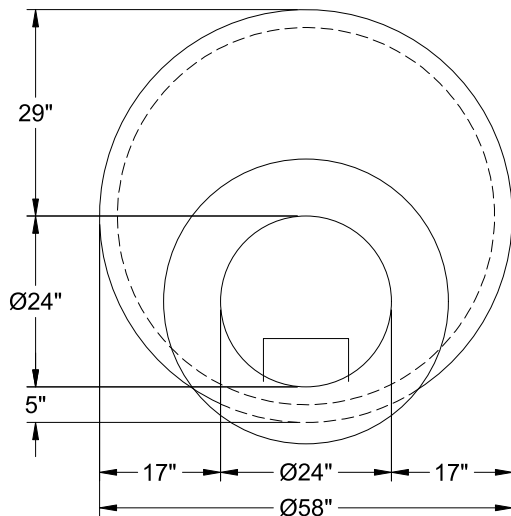

48" - ECC CONE w/ 24" HOLE F/G - 24" - (P2)

Coating (Int):  
 Coating (Ext):

Seam Up: Flat  
 Seam Dn: Groove

Wall Thickness: 5"

Height (Ext): 24"

Weight (Net): 1550 lb  
 Volume (Net): 0.33cu.yd