

Job Name: 25-4337 - Maywood Phase13
 Job Location: Bardstown, KY
 Contractor: Buzick Construction

Plant: 100

12/9/2025 11:21:18 AM

Tech: J. Horsley - F

PC: C. Goff



Structure ID: A11

P1 MH048BA30

MH BASE T/n

- P3) 24" - CASTING HEIGHT - 7"
- P2) 48" - ECC CONE w/ 24" HOLE F/G - 24"
- P1) 48" - MH BASE T/n - 30"
- 1) JOINT WRAP - 0.065"x6"x50' CONSEAL CS212
- 1) JOINT WRAP PRIMER - CONSEAL CS-75 (1 gal.)
- 1) 48" - MH INVERT CHANNEL - FULL HEIGHT
- 1) 48" - Conseal CS-102 1.00" (Double)
- 1) PSX - 12-08 NYLO
- 4) MH Step ML-10-TDS-NCR - 10"

0 lb
 1550 lb
 3378 lb
 0 lb
 0 lb
 1440 lb
 0 lb
 8 lb
 0 lb

 Structure Total: 6376 lb

- Structure Notes:**
1. PER ASTM C-478 SPECIFICATIONS
 2. CONCRETE: 4,000 PSI AT 28 DAYS
 3. REINFORCEMENT: PER ASTM A615
 4. CASTING SUPPLIED BY OTHERS (HOE MC-350 FRAME & COVER "SANITARY")

Rim: 705' Rim to Invert: 5' Slack: 1" Sump: 2" Step Position: 0°

Position	Elev	Angle	Ext. (cw)	Pipe	Pipe OD	Connector	Hole	Horz Size	Up ()	Offset
Invert 1	700'	0°	0"	8" PVC SDR35	8.5"	PSX 12-08 NYLO	12"	12.129"	0"	0"
Invert 2										
Invert 3										
Invert 4										
Invert 5										
Invert 6										
Invert 7										
Invert 8										

RIGHT-SIDE UP VIEW (int. dimensions)

UPSIDE-DOWN VIEW (int. dimensions)

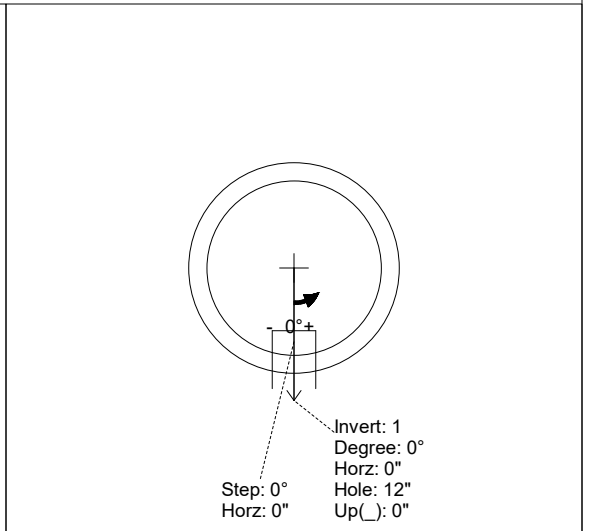
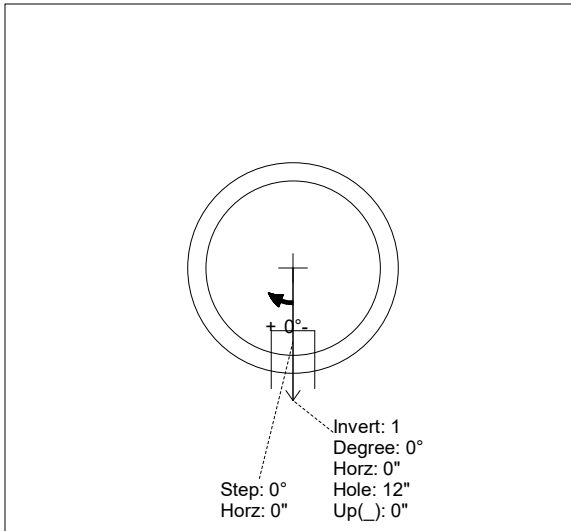
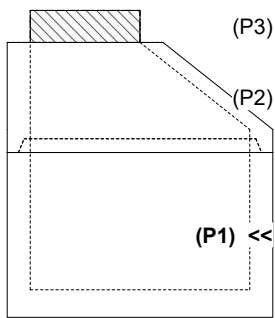

INSIDE WALL DIMENSIONS

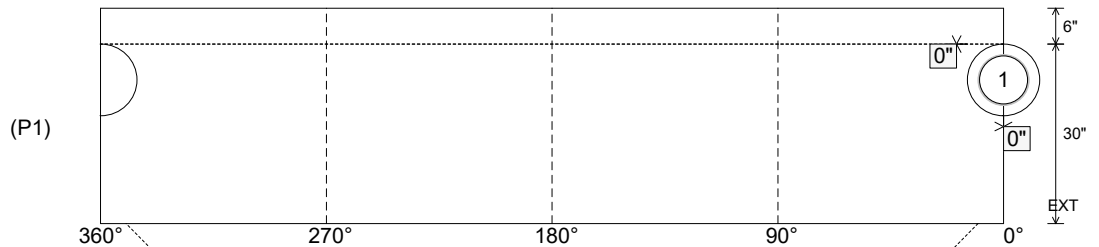

Coating (Int):
 Coating (Ext):

Seam Up: Tongue
 Seam Dn: n/a

Wall Thickness: 5"
 Floor Height: 6"

Height (Int): 30"
 Height (Ext): 36"

Weight (Net): 3378 lb
 Volume (Net): 0.86cu.yd

Structure ID: A11

P1 MH048BA30

MH BASE T/n

P3) 24" - CASTING HEIGHT - 7" P2) 48" - ECC CONE w/ 24" HOLE F/G - 24" P1) 48" - MH BASE T/n - 30" 1) JOINT WRAP - 0.065"x6"x50' CONSEAL CS212 1) JOINT WRAP PRIMER - CONSEAL CS-75 (1 gal.) 1) 48" - MH INVERT CHANNEL - FULL HEIGHT 1) 48" - Conseal CS-102 1.00" (Double) 1) PSX - 12-08 NYLO 4) MH Step ML-10-TDS-NCR - 10"	0 lb 1550 lb 3378 lb 0 lb 0 lb 1440 lb 0 lb 8 lb 0 lb ----- Structure Total: 6376 lb
---	--

Structure Notes:

1. PER ASTM C-478 SPECIFICATIONS
2. CONCRETE: 4,000 PSI AT 28 DAYS
3. REINFORCEMENT: PER ASTM A615
4. CASTING SUPPLIED BY OTHERS (HOE MC-350 FRAME & COVER "SANITARY")

Rim: 705' Rim to Invert: 5' Slack: 1" Sump: 2" Step Position: 0°

Position	Elev	Angle	Ext. (cw)	Pipe	Pipe OD	Connector	Hole	Horz Size	Up (↓)	Offset
Invert 1	700'	0°	0"	8" PVC SDR35	8.5"	PSX 12-08 NYLO	12"	12.129"	0"	0"
Invert 2										
Invert 3										
Invert 4										
Invert 5										
Invert 6										
Invert 7										
Invert 8										

RIGHT-SIDE UP VIEW (int. dimensions)

UPSIDE-DOWN VIEW (int. dimenions)

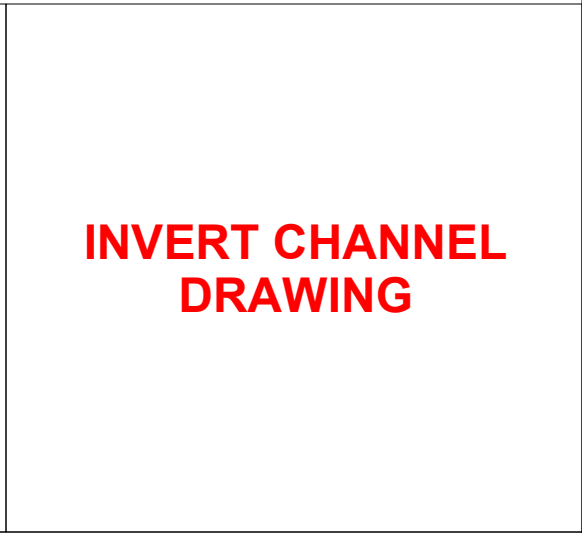
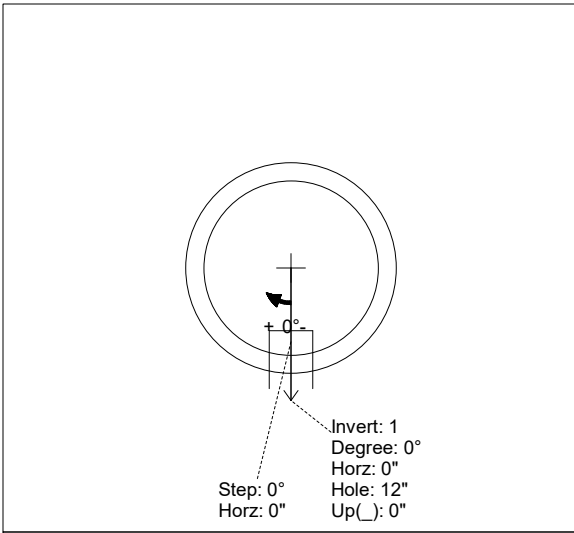
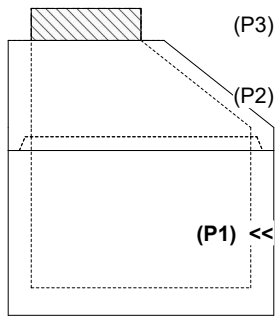

INSIDE WALL DIMENSIONS

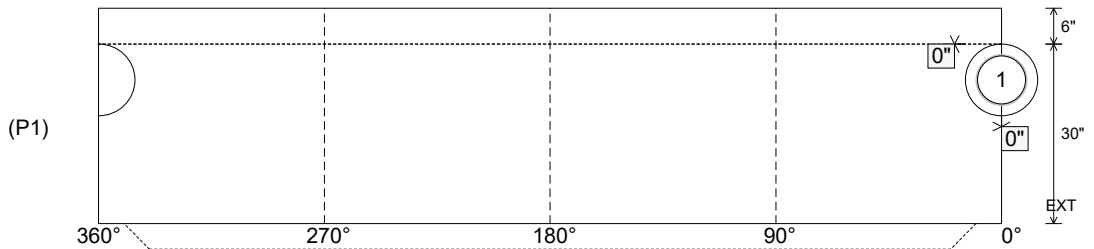

Coating (Int): Coating (Ext):	Seam Up: Tongue Seam Dn: n/a	Wall Thickness: 5" Floor Height: 6"	Height (Int): 30" Height (Ext): 36"	Weight (Net): 3378 lb Volume (Net): 0.86cu.yd
----------------------------------	---------------------------------	--	--	--