

Job Name: 25-4337 - Maywood Phase13  
 Job Location: Bardstown, KY  
 Contractor: Buzick Construction

Plant: 100

Tech: J. Horsley - F

12/9/2025 11:29:27 AM

PC: C. Goff



**Structure ID: A10**

**P2 MH048CN42**

**ECC CONE w/ 24" HOLE F/G**

- P4) 24" - CASTING HEIGHT - 7"
- P3) 24" - GRADE RING F/F - 4"
- P2) 48" - ECC CONE w/ 24" HOLE F/G - 42"
- P1) 48" - MH BASE T/n - 30"
- 1) JOINT WRAP - 0.065"x6"x50' CONSEAL CS212
- 1) JOINT WRAP PRIMER - CONSEAL CS-75 (1 gal.)
- 1) 48" - MH INVERT CHANNEL - FULL HEIGHT
- 1) 48" - Conseal CS-102 1.00" (Double)
- 2) PSX - 12-08 NYLO
- 6) MH Step ML-10-TDS-NCR - 10"

0 lb  
 270 lb  
 3200 lb  
 3330 lb  
 0 lb  
 0 lb  
 1440 lb  
 0 lb  
 16 lb  
 0 lb  
 -----  
 Structure Total: 8256 lb

Structure Notes:  
 1. PER ASTM C-478 SPECIFICATIONS  
 2. CONCRETE: 4,000 PSI AT 28 DAYS  
 3. REINFORCEMENT: PER ASTM A615  
 4. CASTING SUPPLIED BY OTHERS (HOE MC-350  
 FRAME & COVER "SANITARY"

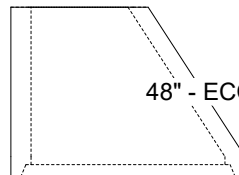
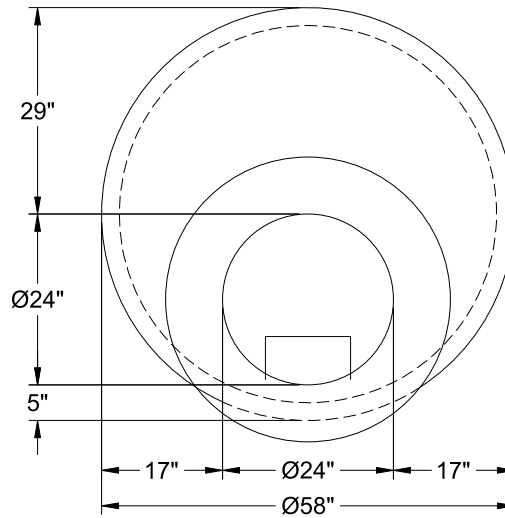

48" - ECC CONE w/ 24" HOLE F/G - 42" - (P2)

Coating (Int):  
 Coating (Ext):

Seam Up: Flat  
 Seam Dn: Groove

Wall Thickness: 5"

Height (Ext): 42"

Weight (Net): 3200 lb  
 Volume (Net): 0.5cu.yd