

Structure ID: A10

P1 MH048BA30

MH BASE T/n

P4) 24" - CASTING HEIGHT - 7" P3) 24" - GRADE RING F/F - 4" P2) 48" - ECC CONE w/ 24" HOLE F/G - 42" P1) 48" - MH BASE T/n - 30" 1) JOINT WRAP - 0.065"x6"x50' CONSEAL CS212 1) JOINT WRAP PRIMER - CONSEAL CS-75 (1 gal.) 1) 48" - MH INVERT CHANNEL - FULL HEIGHT 1) 48" - Conseal CS-102 1.00" (Double) 2) PSX - 12-08 NYLO 6) MH Step ML-10-TDS-NCR - 10"	0 lb 270 lb 3200 lb 3330 lb 0 lb 0 lb 1440 lb 0 lb 16 lb 0 lb ----- Structure Total: 8256 lb	Structure Notes: 1. PER ASTM C-478 SPECIFICATIONS 2. CONCRETE: 4,000 PSI AT 28 DAYS 3. REINFORCEMENT: PER ASTM A615 4. CASTING SUPPLIED BY OTHERS (HOE MC-350 FRAME & COVER "SANITARY")
--	---	--

Rim: 705.11' Rim to Invert: 6.78' Slack: 0.36" Sump: 2" Step Position: 0°

Position	Elev	Angle	Ext. (cw)	Pipe	Pipe OD	Connector	Hole	Horz Size	Up ()	Offset
Invert 1	698.33'	0°	0"	8" PVC SDR35	8.5"	PSX 12-08 NYLO	12"	12.129"	0"	0"
Invert 2	698.43'	232°	117.426"	8" PVC SDR35	8.5"	PSX 12-08 NYLO	12"	12.129"	1.2"	0"
Invert 3										
Invert 4										
Invert 5										
Invert 6										
Invert 7										
Invert 8										

RIGHT-SIDE UP VIEW (int. dimensions)

UPSIDE-DOWN VIEW (int. dimensions)

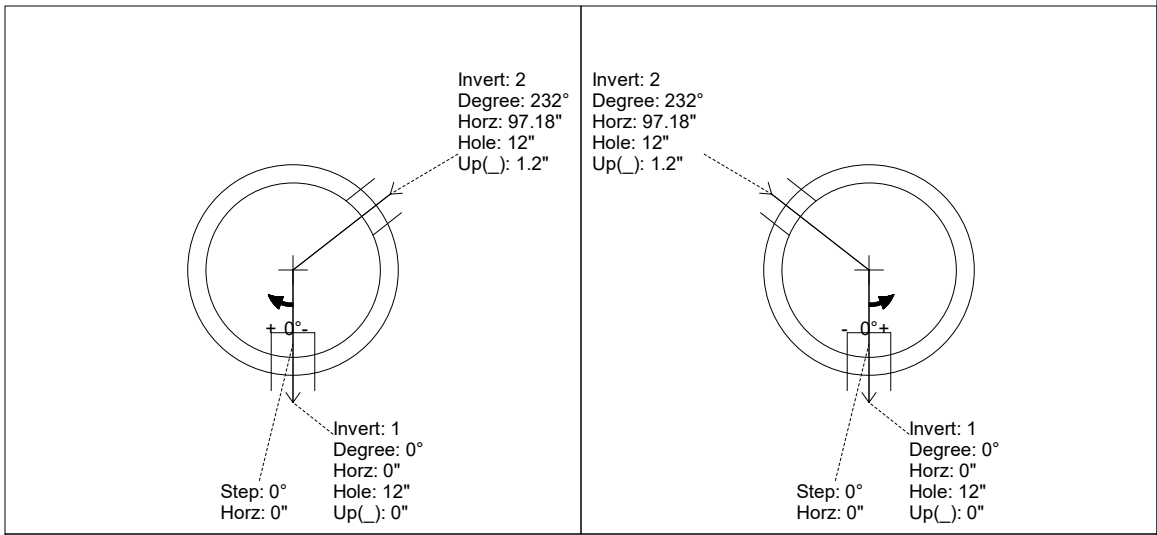
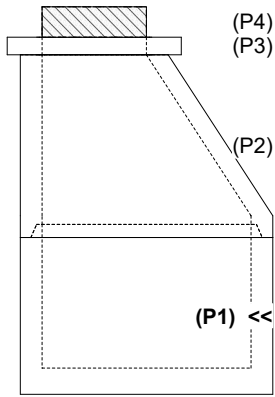

INSIDE WALL DIMENSIONS

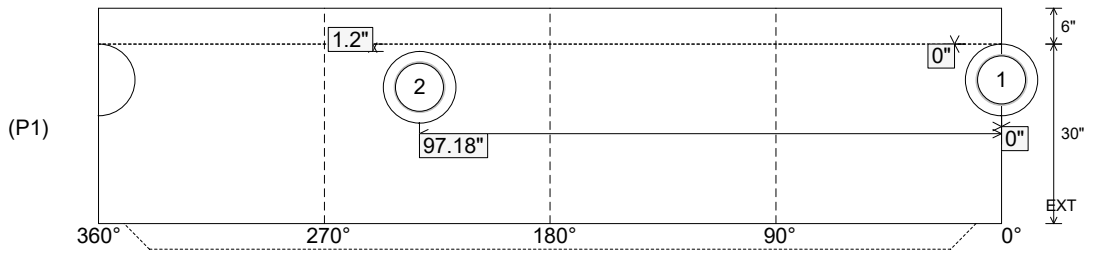

Coating (Int): Coating (Ext):	Seam Up: Tongue Seam Dn: n/a	Wall Thickness: 5" Floor Height: 6"	Height (Int): 30" Height (Ext): 36"	Weight (Net): 3330 lb Volume (Net): 0.85cu.yd
----------------------------------	---------------------------------	--	--	--

Structure ID: A10

P1 MH048BA30

MH BASE T/n

P4) 24" - CASTING HEIGHT - 7" P3) 24" - GRADE RING F/F - 4" P2) 48" - ECC CONE w/ 24" HOLE F/G - 42" P1) 48" - MH BASE T/n - 30" 1) JOINT WRAP - 0.065"x6"x50' CONSEAL CS212 1) JOINT WRAP PRIMER - CONSEAL CS-75 (1 gal.) 1) 48" - MH INVERT CHANNEL - FULL HEIGHT 1) 48" - Conseal CS-102 1.00" (Double) 2) PSX - 12-08 NYLO 6) MH Step ML-10-TDS-NCR - 10"	0 lb 270 lb 3200 lb 3330 lb 0 lb 0 lb 1440 lb 0 lb 16 lb 0 lb ----- Structure Total: 8256 lb
--	---

Structure Notes:
 1. PER ASTM C-478 SPECIFICATIONS
 2. CONCRETE: 4,000 PSI AT 28 DAYS
 3. REINFORCEMENT: PER ASTM A615
 4. CASTING SUPPLIED BY OTHERS (HOE MC-350 FRAME & COVER "SANITARY")

Rim: 705.11' Rim to Invert: 6.78' Slack: 0.36" Sump: 2" Step Position: 0°

Position	Elev	Angle	Ext. (cw)	Pipe	Pipe OD	Connector	Hole	Horz Size	Up ()	Offset
Invert 1	698.33'	0°	0"	8" PVC SDR35	8.5"	PSX 12-08 NYLO	12"	12.129"	0"	0"
Invert 2	698.43'	232°	117.426"	8" PVC SDR35	8.5"	PSX 12-08 NYLO	12"	12.129"	1.2"	0"
Invert 3										
Invert 4										
Invert 5										
Invert 6										
Invert 7										
Invert 8										

RIGHT-SIDE UP VIEW (int. dimensions) UPSIDE-DOWN VIEW (int. dimenions)

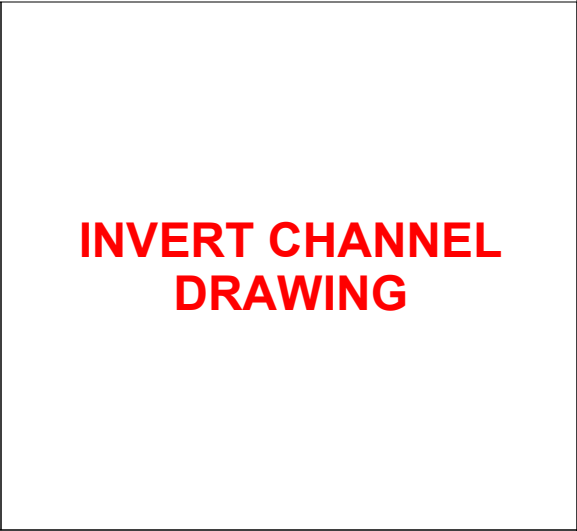
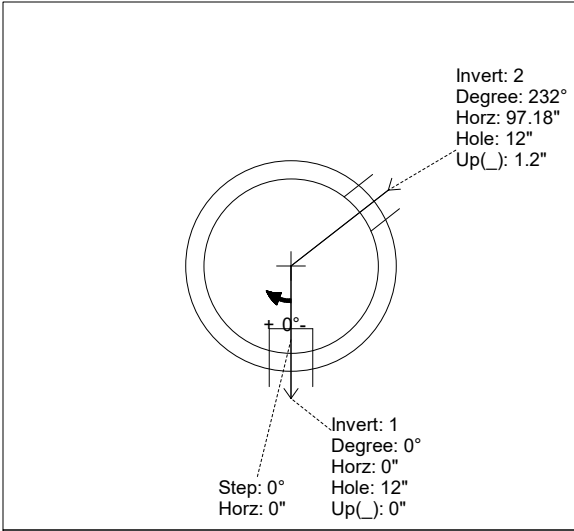
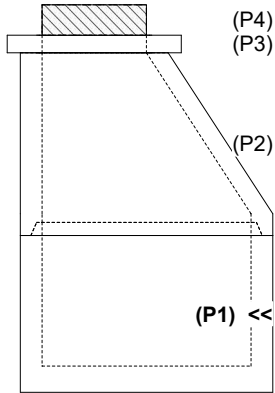

INSIDE WALL DIMENSIONS

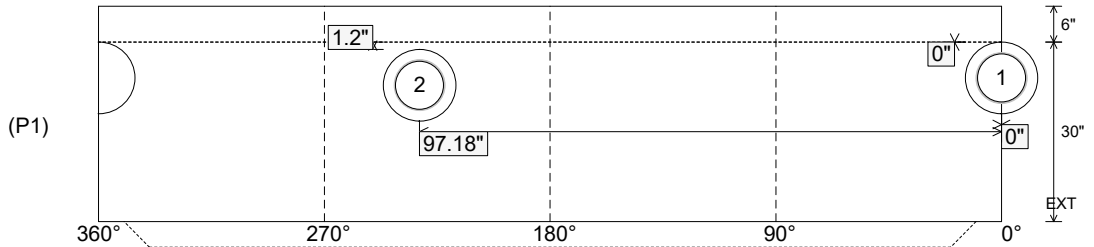

Coating (Int): Coating (Ext):	Seam Up: Tongue Seam Dn: n/a	Wall Thickness: 5" Floor Height: 6"	Height (Int): 30" Height (Ext): 36"	Weight (Net): 3330 lb Volume (Net): 0.85cu.yd
----------------------------------	---------------------------------	--	--	--