

Job Name: 25-4333 WTP Manholes  
 Job Location: Clarksville, TN  
 Contractor: Judy Construction Co.

Plant: Beaver Dam  
 2/16/2026 8:20:38 AM

Tech: S. Felletter  
 PC: E. Bradley



**Structure ID: SSMH 9-5**

**P3 MH048CN42CDARED**

**ECC CONE w/ 24" HOLE, w/ConBlock-CDA Red F/G**

P4) 24" - CASTING HEIGHT - 7"	0 lb
P3) 48" - ECC CONE w/ 24" HOLE, w/ConBlock-CDA Red F/G - 42"	3116 lb
P2) 48" - MH RISER w/DROP/ConBlock-CDA Red T/G - 60"	4168 lb
P1) 48" - MH BASE w/DROP/FLG Cust. Ht. w/ConBlock-CDA Red T/n - 29"	5920 lb
1) JOINT WRAP - 0.065"x6"x50' CONSEAL CS212	0 lb
1) JOINT WRAP PRIMER - CONSEAL CS-75 (1 gal.)	0 lb
1) ADMIXTURE CONBLOCK CDA RED	0 lb
1) 48" - MH INVERT CHANNEL w/ConBlock-CDA Red - FULL HEIGHT	1440 lb
1) Conseal CS-102 1.00" (Single)	0 lb
1) CASTING - JBS 1150 F/C SANITARY	250 lb
2) 48" - Hamilton Kent MH Gasket	0 lb
1) Quik-Lok - QL-08-C	1 lb
1) Drop Tee - 8" PVC	0 lb
1) Drop Elbow - 8" PVC	0 lb
Structure Total:	14895 lb

Structure Notes:  
 1. PER ASTM C478 SPECIFICATIONS.  
 2. CONCRETE = 4,000 PSI AT 28 DAYS.  
 3. CASTING JBS 1150 F/C SANITARY PROVIDED BY ICAST.  
 4. EXTERIOR DROP ASSEMBLY @ 130.

REINFORCING PER ASTM A615 (GRADE 60).  
 - CONE (As .12)  
 - RISER/WALLS (As .12)  
 - FLOOR (As .31) #5 BARS AT 12" C.C.E.W.

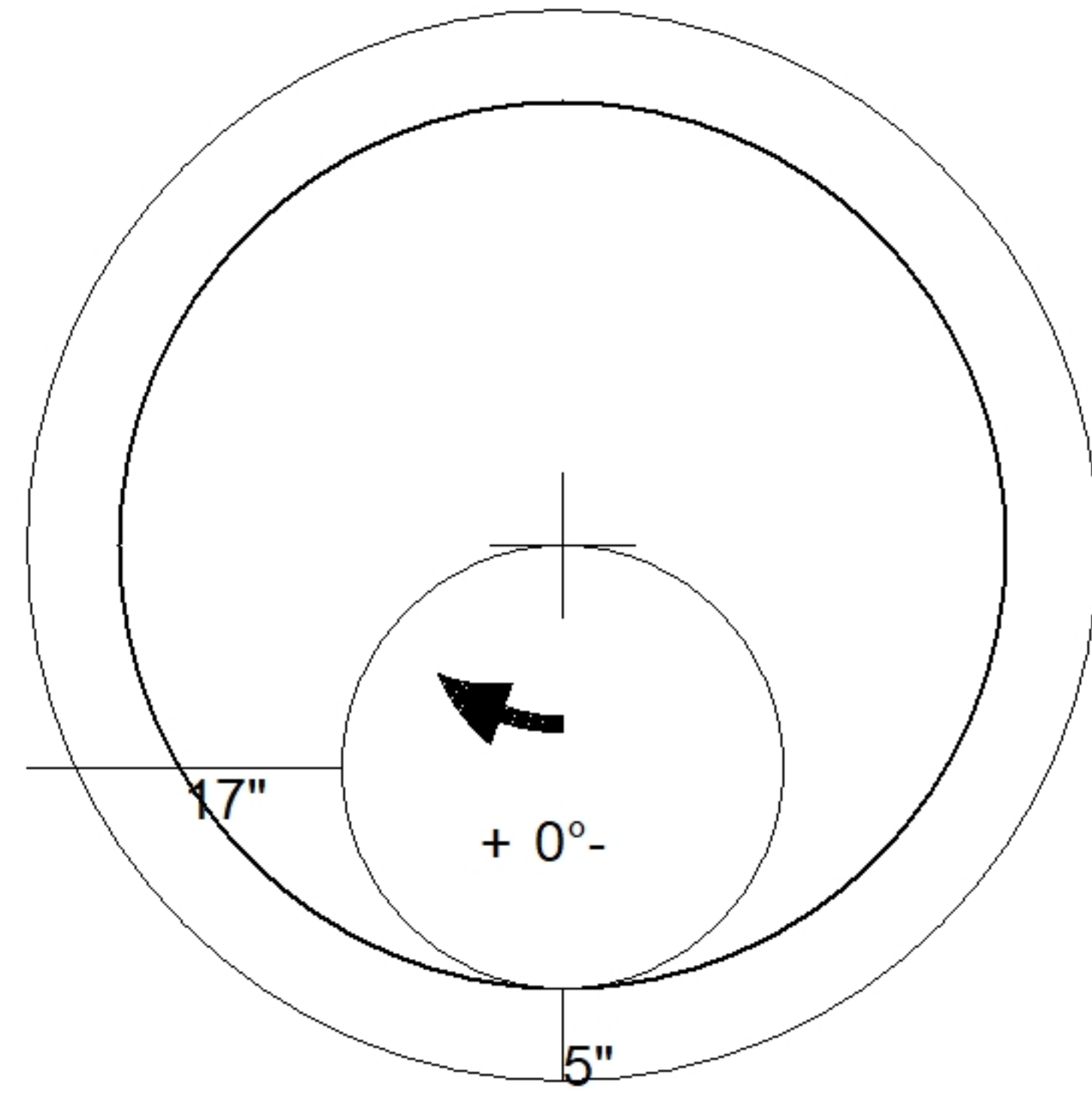

48" - ECC CONE w/ 24" HOLE, w/ConBlock-CDA Red F/G - 42" - (P3)

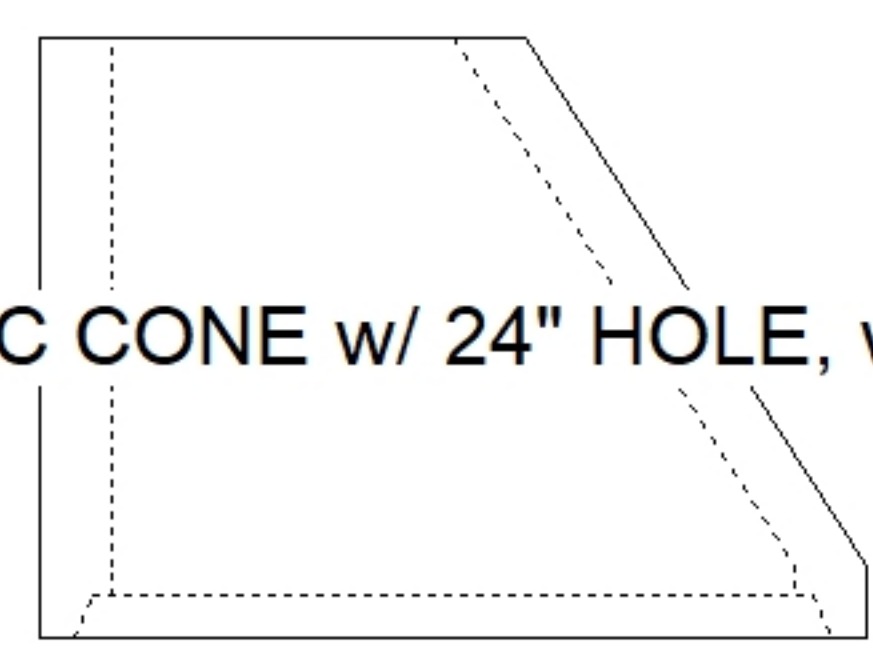

Coating (Int): Coating (Ext):	Seam Up: Flat Seam Dn: Groove	Wall Thickness: 5"	Height (Ext): 42"	Weight (Net): 3116 lb Volume (Net): 0.8cu.yd
----------------------------------	----------------------------------	--------------------	-------------------	---