

Job Name: 25-4333 WTP Manholes
 Job Location: Clarksville, TN
 Contractor: Judy Construction Co.

Plant: Beaver Dam
 2/13/2026 10:37:55 AM

Tech: S. Felletter
 PC: E. Bradley



Structure ID: SSMH 9-5

P1 MH048BAEVFD-CDARED

MH BASE w/DROP/FLG Cust. Ht. w/ConBlock-CDA Red

P4) 24" - CASTING HEIGHT - 7"	0 lb
P3) 48" - ECC CONE w/ 24" HOLE, w/ConBlock-CDA Red F/G - 42"	3116 lb
P2) 48" - MH RISER w/DROP/ConBlock-CDA Red T/G - 60"	4168 lb
P1) 48" - MH BASE w/DROP/FLG Cust. Ht. w/ConBlock-CDA Red T/n - 29"	5920 lb
1) JOINT WRAP - 0.065"x6"x50' CONSEAL CS212	0 lb
1) JOINT WRAP PRIMER - CONSEAL CS-75 (1 gal.)	0 lb
1) ADMIXTURE CONBLOCK CDA RED	0 lb
1) 48" - MH INVERT CHANNEL w/ConBlock-CDA Red - FULL HEIGHT	1440 lb
1) Conseal CS-102 1.00" (Single)	0 lb
1) CASTING - JBS 1150 F/C SANITARY	250 lb
2) 48" - Hamilton Kent MH Gasket	0 lb
1) Quik-Lok - QL-08-C	1 lb
1) Drop Tee - 8" PVC	0 lb
1) Drop Elbow - 8" PVC	0 lb
Structure Total:	14895 lb

Structure Notes:
 1. PER ASTM C478 SPECIFICATIONS.
 2. CONCRETE = 4,000 PSI AT 28 DAYS.
 3. CASTING JBS 1150 F/C SANITARY PROVIDED BY ICAST.
 4. EXTERIOR DROP ASSEMBLY @ 130.

 REINFORCING PER ASTM A615 (GRADE 60).
 - CONE (As .12)
 - RISER/WALLS (As .12)
 - FLOOR (As .31) #5 BARS AT 12" C.C.E.W.

Rim: 508.1' Rim to Invert: 11.4' Slack: 0.8" Sump: 2" Step Position:

Position	Elev	Angle	Ext. (cw)	Pipe	Pipe OD	Connector	Hole	Horz Size	Up ()	Offset
Invert 1	496.7'	0°	0"	8" PVC SDR26	8.5"	Quik-Lok QL-08-C	10.75"	10.842"	0.625"	0"
Invert 2										
Invert 3	496.8'	130°	65.799"	8" PVC SDR35	8.5"	Drop Elbow 8" PVC	8.5"	8.545"	2.95"	0"
Invert 4										
Invert 5										
Invert 6										
Invert 7										
Invert 8										

RIGHT-SIDE UP VIEW (int. dimensions)

UPSIDE-DOWN VIEW (int. dimensions)

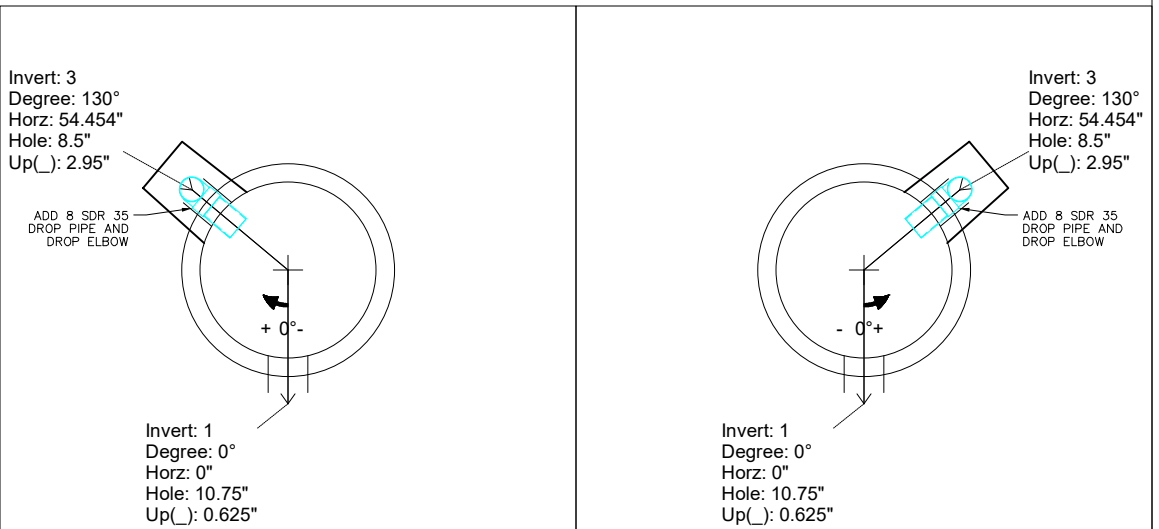

INSIDE WALL DIMENSIONS

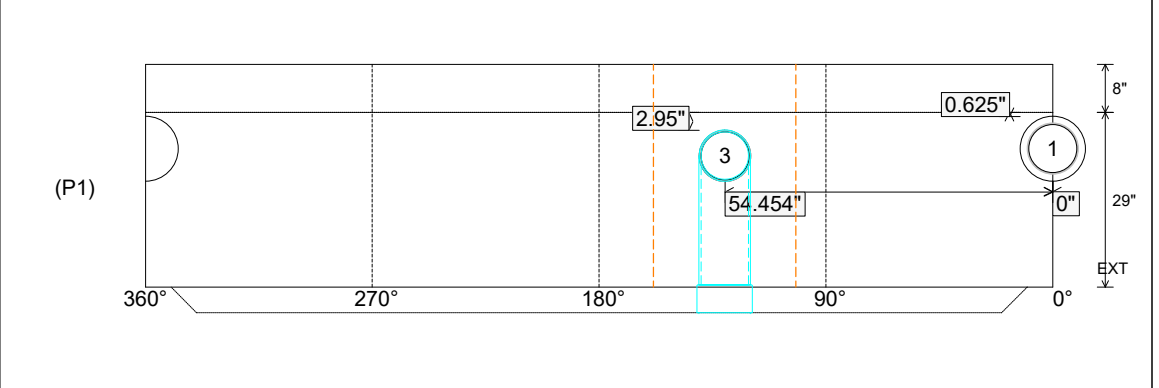

Coating (Int): Coating (Ext):	Seam Up: Tongue Seam Dn: n/a	Wall Thickness: 5" Floor Height: 8"	Height (Int): 29" Height (Ext): 37"	Weight (Net): 5920 lb Volume (Net): 1.51cu.yd
----------------------------------	---------------------------------	--	--	--

Job Name: 25-4333 WTP Manholes
 Job Location: Clarksville, TN
 Contractor: Judy Construction Co.

Plant: Beaver Dam
 2/13/2026 10:37:55 AM

Tech: S. Felletter
 PC: E. Bradley



Structure ID: SSMH 9-5

P1 MH048BAEVFD-CDARED

MH BASE w/DROP/FLG Cust. Ht. w/ConBlock-CDA Red

- P4) 24" - CASTING HEIGHT - 7"
- P3) 48" - ECC CONE w/ 24" HOLE, w/ConBlock-CDA Red F/G - 42"
- P2) 48" - MH RISER w/DROP/ConBlock-CDA Red T/G - 60"
- P1) 48" - MH BASE w/DROP/FLG Cust. Ht. w/ConBlock-CDA Red T/n - 29"
- 1) JOINT WRAP - 0.065"x6"x50' CONSEAL CS212
- 1) JOINT WRAP PRIMER - CONSEAL CS-75 (1 gal.)
- 1) ADMIXTURE CONBLOCK CDA RED
- 1) 48" - MH INVERT CHANNEL w/ConBlock-CDA Red - FULL HEIGHT
- 1) Conseal CS-102 1.00" (Single)
- 1) CASTING - JBS 1150 F/C SANITARY
- 2) 48" - Hamilton Kent MH Gasket
- 1) Quik-Lok - QL-08-C
- 1) Drop Tee - 8" PVC
- 1) Drop Elbow - 8" PVC

0 lb
 3116 lb
 4168 lb
 5920 lb
 0 lb
 0 lb
 0 lb
 1440 lb
 0 lb
 250 lb
 0 lb
 1 lb
 0 lb
 0 lb

 Structure Total: 14895 lb

Structure Notes:
 1. PER ASTM C478 SPECIFICATIONS.
 2. CONCRETE = 4,000 PSI AT 28 DAYS.
 3. CASTING JBS 1150 F/C SANITARY PROVIDED BY ICAST.
 4. EXTERIOR DROP ASSEMBLY @ 130.

REINFORCING PER ASTM A615 (GRADE 60).
 - CONE (As .12)
 - RISER/WALLS (As .12)
 - FLOOR (As .31) #5 BARS AT 12" C.C.E.W.

DROP ASSEMBLY DRAWING

Rim: 508.1' Rim to Invert: 11.4' Slack: 0.8" Sump: 2" Step Position:

Position	Elev	Angle	Ext. (cw)	Pipe	Pipe OD	Connector	Hole	Horz Size	Up ()	Offset
Invert 1	496.7'	0°	0"	8" PVC SDR26	8.5"	Quik-Lok QL-08-C	10.75"	10.842"	0.625"	0"
Invert 2										
Invert 3	496.8'	130°	65.799"	8" PVC SDR35	8.5"	Drop Elbow 8" PVC	8.5"	8.545"	2.95"	0"
Invert 4										
Invert 5										
Invert 6										
Invert 7										
Invert 8										

RIGHT-SIDE UP VIEW (int. dimensions)

UPSIDE-DOWN VIEW (int. dimensions)

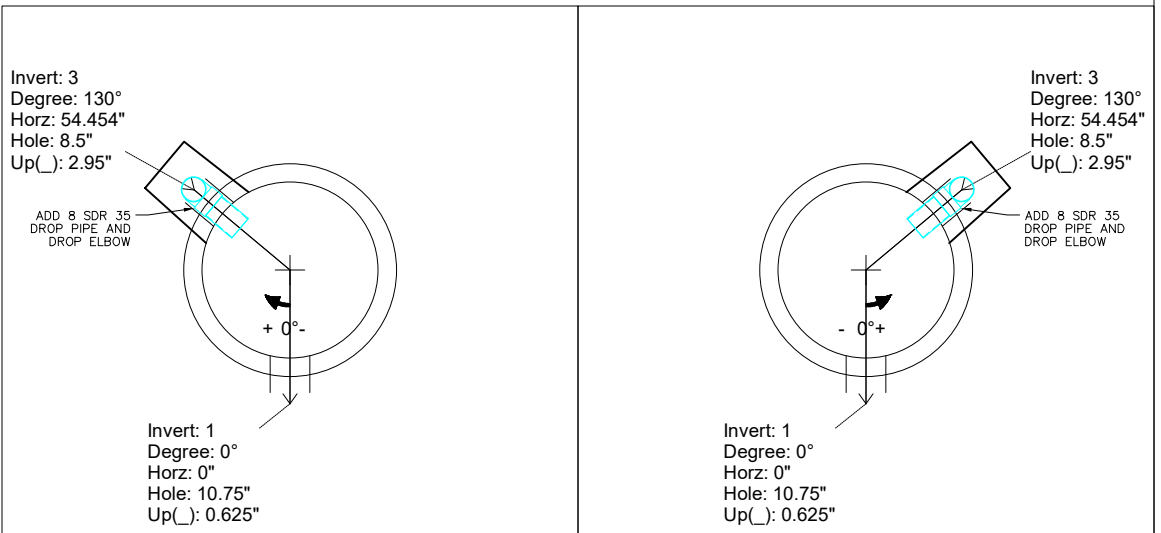

INSIDE WALL DIMENSIONS

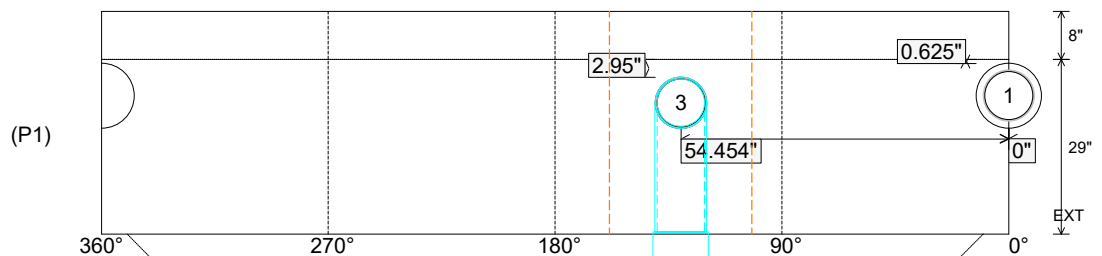

Coating (Int):
 Coating (Ext):

Seam Up: Tongue
 Seam Dn: n/a

Wall Thickness: 5"
 Floor Height: 8"

Height (Int): 29"
 Height (Ext): 37"

Weight (Net): 5920 lb
 Volume (Net): 1.51cu.yd

Job Name: 25-4333 WTP Manholes
 Job Location: Clarksville, TN
 Contractor: Judy Construction Co.

Plant: Beaver Dam

Tech: S. Felletter

2/13/2026 10:37:55 AM

PC: E. Bradley



Structure ID: SSMH 9-5

P1 MH048BAEVFD-CDARED

MH BASE w/DROP/FLG Cust. Ht. w/ConBlock-CDA Red

- P4) 24" - CASTING HEIGHT - 7"
- P3) 48" - ECC CONE w/ 24" HOLE, w/ConBlock-CDA Red F/G - 42"
- P2) 48" - MH RISER w/DROP/ConBlock-CDA Red T/G - 60"
- P1) 48" - MH BASE w/DROP/FLG Cust. Ht. w/ConBlock-CDA Red T/n - 29"
- 1) JOINT WRAP - 0.065"x6"x50' CONSEAL CS212
- 1) JOINT WRAP PRIMER - CONSEAL CS-75 (1 gal.)
- 1) ADMIXTURE CONBLOCK CDA RED
- 1) 48" - MH INVERT CHANNEL w/ConBlock-CDA Red - FULL HEIGHT
- 1) Conseal CS-102 1.00" (Single)
- 1) CASTING - JBS 1150 F/C SANITARY
- 2) 48" - Hamilton Kent MH Gasket
- 1) Quik-Lok - QL-08-C
- 1) Drop Tee - 8" PVC
- 1) Drop Elbow - 8" PVC

0 lb
 3116 lb
 4168 lb
 5920 lb
 0 lb
 0 lb
 0 lb
 1440 lb
 0 lb
 250 lb
 0 lb
 1 lb
 0 lb
 0 lb

Structure Notes:
 1. PER ASTM C478 SPECIFICATIONS.
 2. CONCRETE = 4,000 PSI AT 28 DAYS.
 3. CASTING JBS 1150 F/C SANITARY PROVIDED BY ICAST.
 4. EXTERIOR DROP ASSEMBLY @ 130.

REINFORCING PER ASTM A615 (GRADE 60).
 - CONE (As .12)
 - RISER/WALLS (As .12)
 - FLOOR (As .31) #5 BARS AT 12" C.C.E.W.

**INVERT CHANNEL DRAWING.
 FULL HEIGHT INVERT**

Structure Total: 14895 lb

Rim: 508.1' Rim to Invert: 11.4' Slack: 0.8" Sump: 2" Step Position:

Position	Elev	Angle	Ext. (cw)	Pipe	Pipe OD	Connector	Hole	Horz Size	Up ()	Offset
Invert 1	496.7'	0°	0"	8" PVC SDR26	8.5"	Quik-Lok QL-08-C	10.75"	10.842"	0.625"	0"
Invert 2										
Invert 3	496.8'	130°	65.799"	8" PVC SDR35	8.5"	Drop Elbow 8" PVC	8.5"	8.545"	2.95"	0"
Invert 4										
Invert 5										
Invert 6										
Invert 7										
Invert 8										

RIGHT-SIDE UP VIEW (int. dimensions)

UPSIDE-DOWN VIEW (int. dimensions)

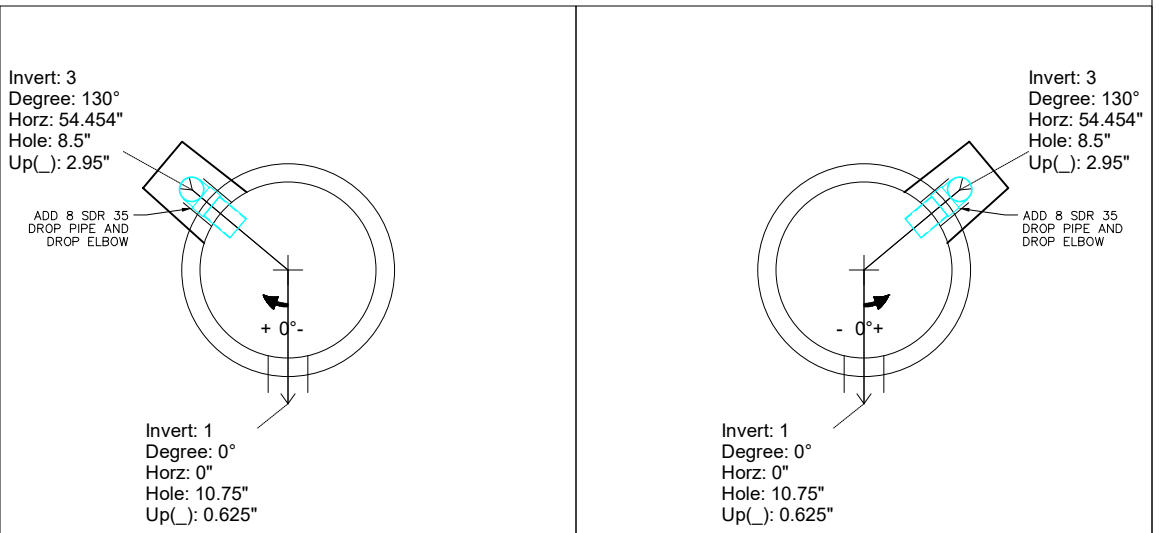

INSIDE WALL DIMENSIONS

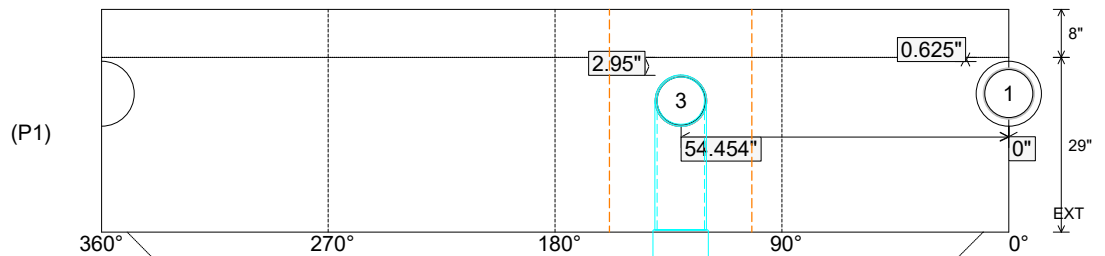

Coating (Int):
 Coating (Ext):

Seam Up: Tongue
 Seam Dn: n/a

Wall Thickness: 5"
 Floor Height: 8"

Height (Int): 29"
 Height (Ext): 37"

Weight (Net): 5920 lb
 Volume (Net): 1.51cu.yd