

Job Name: 25-4331 - WING 18 RISERS
 Job Location: MINNEAPOLIS, MN
 Contractor: Contech Engineering Solutions

Plant: BEAVER DAM

Tech: J. COPPAGE

11/12/2025 1:33:16 PM

PC: T. SEKULA



Structure ID: 4-54331-A

P1 MH036LD10-30ECC

MH FLAT LID w/30in ECC Hole

P1) 36" - MH FLAT LID w/30in ECC Hole - 10"

Structure Total: 683 lb

- Structure Notes:**
1. PER ASTM C478 SPECIFICATIONS.
 2. CONCRETE = 4,000 PSI AT 28 DAYS.
 3. REINFORCING PER ASTM A615 (GRADE 60).
 - TOP SLAB (As .62) #5 BARS AT 6" C.C.E.W..

CONTECH'S LOGO MUST BE STENCILED ONTO THE STRUCTURE

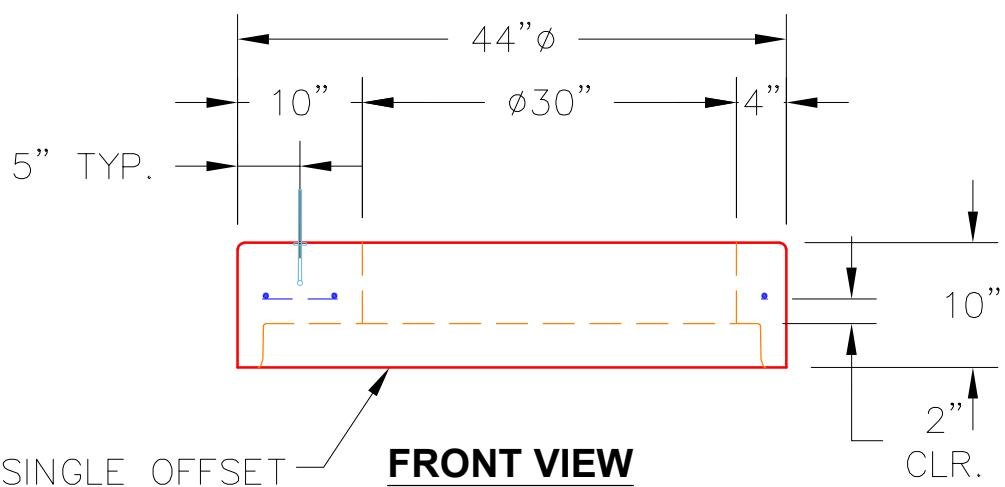
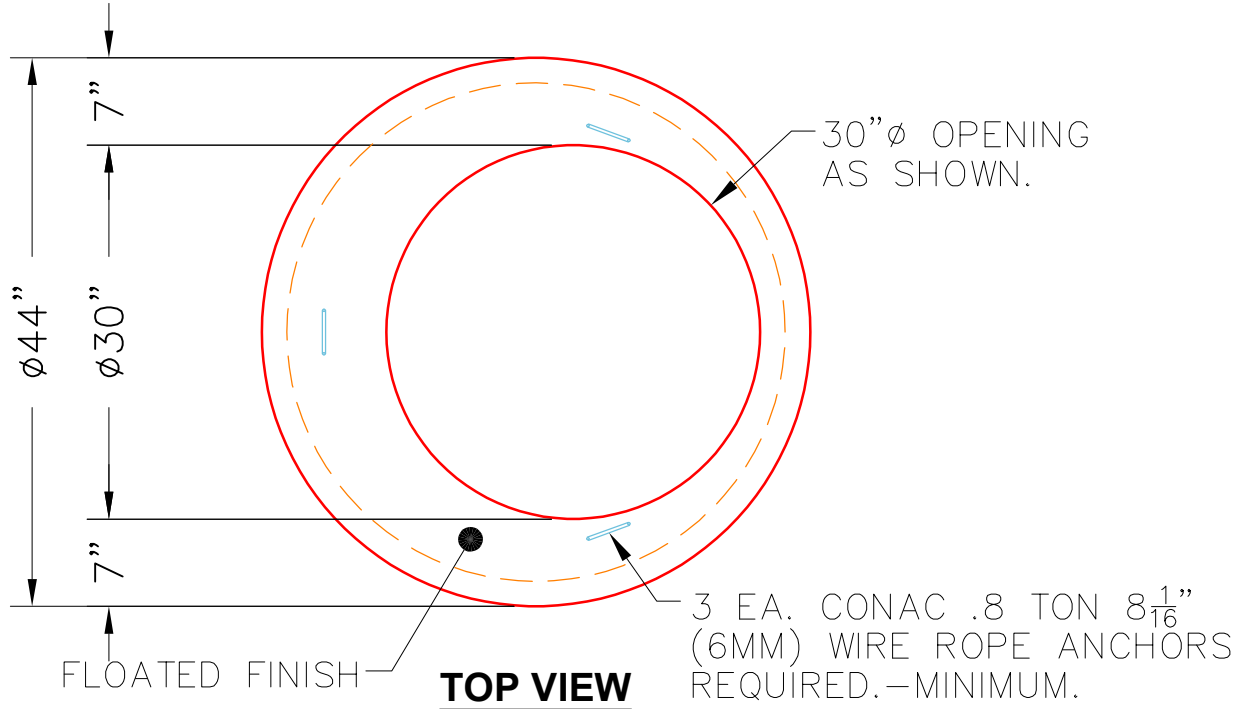

Coating (Int):
Coating (Ext):

Seam Up: Flat
Seam Dn: Groove

Wall Thickness: 4"

Height (Ext): 10"

Weight (Net): 683 lb
Volume (Net): 0.17cu.yd