

Job Name: 25-4327 - 834447 Lou Fusz Toyota Kirkwood  
 Job Location: Saint Louis, MO  
 Contractor: Contech Engineering Solutions

Plant: Beaver Dam  
 10/29/2025 10:23:06 AM

Tech: J. Coppage  
 PC: T. Sekula



**Structure ID: 10-CS-5**

**P2 MH060RSVF**

**MH RISER Custom Ht**

- P5) 30" - CASTING HEIGHT - 4"
- P4) 60" - MH FLAT TOP SPEC. (30" ECC HOLE) - 13"
- P3) 60" - MH RISER NO STEPS - 18"
- P2) 60" - MH RISER Custom Ht - 53"
- P1) 60" - MH BASE - 30"
- 1) PSASSEMBLY
- 1) CVSTENCILING
- 1) KNS CGA-12A - KNS CGA-12A
- 3) 60" - Conseal CS-102 1.00"
- 2) Kor-N-Seal1 - S106-16T

0 lb  
 2589 lb  
 1879 lb  
 5326 lb  
 5865 lb  
 0 lb  
 0 lb  
 0 lb  
 0 lb  
 13 lb  
 -----  
 Structure Total: 15672 lb

**Structure Notes:**  
 (4" TALL CASTING BY OTHERS)  
 LIFTING ANCHORS TO BE INSTALLED ON THE OUTSIDE OF THE STRUCTURE  
 ICAST TO INSTALL THE INTERNALS  
 CONTECH'S LOGO AS WELL AS THE INLET AND OUTLET MUST BE STENCILED ONTO THE STRUCTURE  
 BASE TO BE MECHANICALLY ATTACHED TO THE BOTTOM OF THE CONTROL RISER

Rim: 640.92' Rim to Invert: 5.78' Slack: 5.36" Sump: 54" Step Position:

Position	Elev	Angle	Ext. (cw)	Pipe	Pipe OD	Connector	Hole	Horz Size	Up ( )	Offset
Invert 1	635.14'	270°	169.646"	12" HDPE	14.5"	Kor-N-Seal1 S106-16T	16"	16.196"	17.25"	0"
Invert 2	635.14'	332°	214.63"	12" HDPE	14.5"	Kor-N-Seal1 S106-16T	16"	16.567"	17.25"	6"
Invert 3										
Invert 4										
Invert 5										
Invert 6										
Invert 7										
Invert 8										

**RIGHT-SIDE UP VIEW (int. dimensions)**

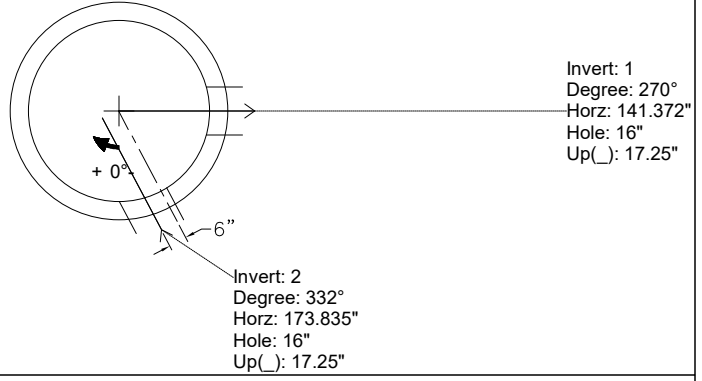
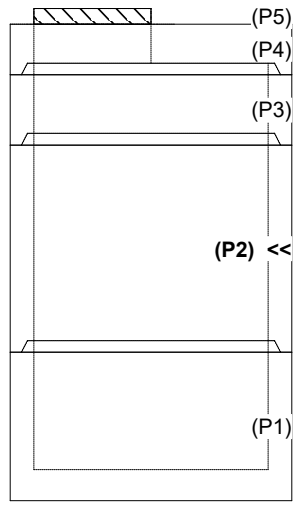

**INSIDE WALL DIMENSIONS**

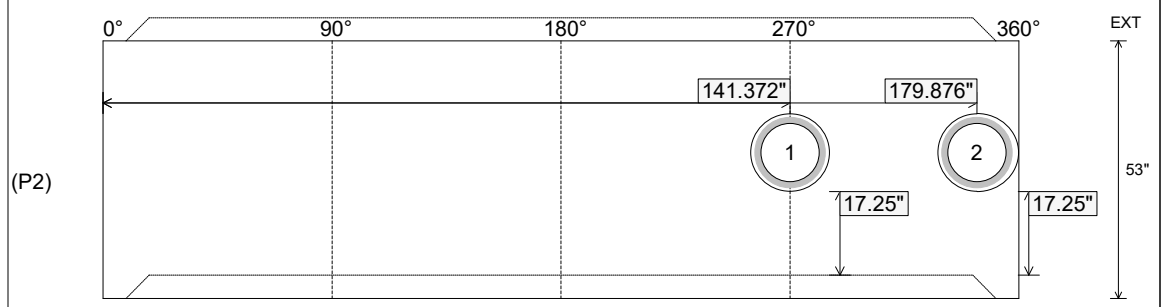

Coating (Int): Coating (Ext):	Seam Up: Tongue Seam Dn: Groove	Wall Thickness: 6" Floor Height: 0"	Height (Int): 53" Height (Ext): 53"	Weight (Net): 5326 lb Volume (Net): 1.36cu.yd
----------------------------------	------------------------------------	----------------------------------------	----------------------------------------	--------------------------------------------------