

THIS DRAWING IS INTENDED TO BE PRINTED IN COLOR.

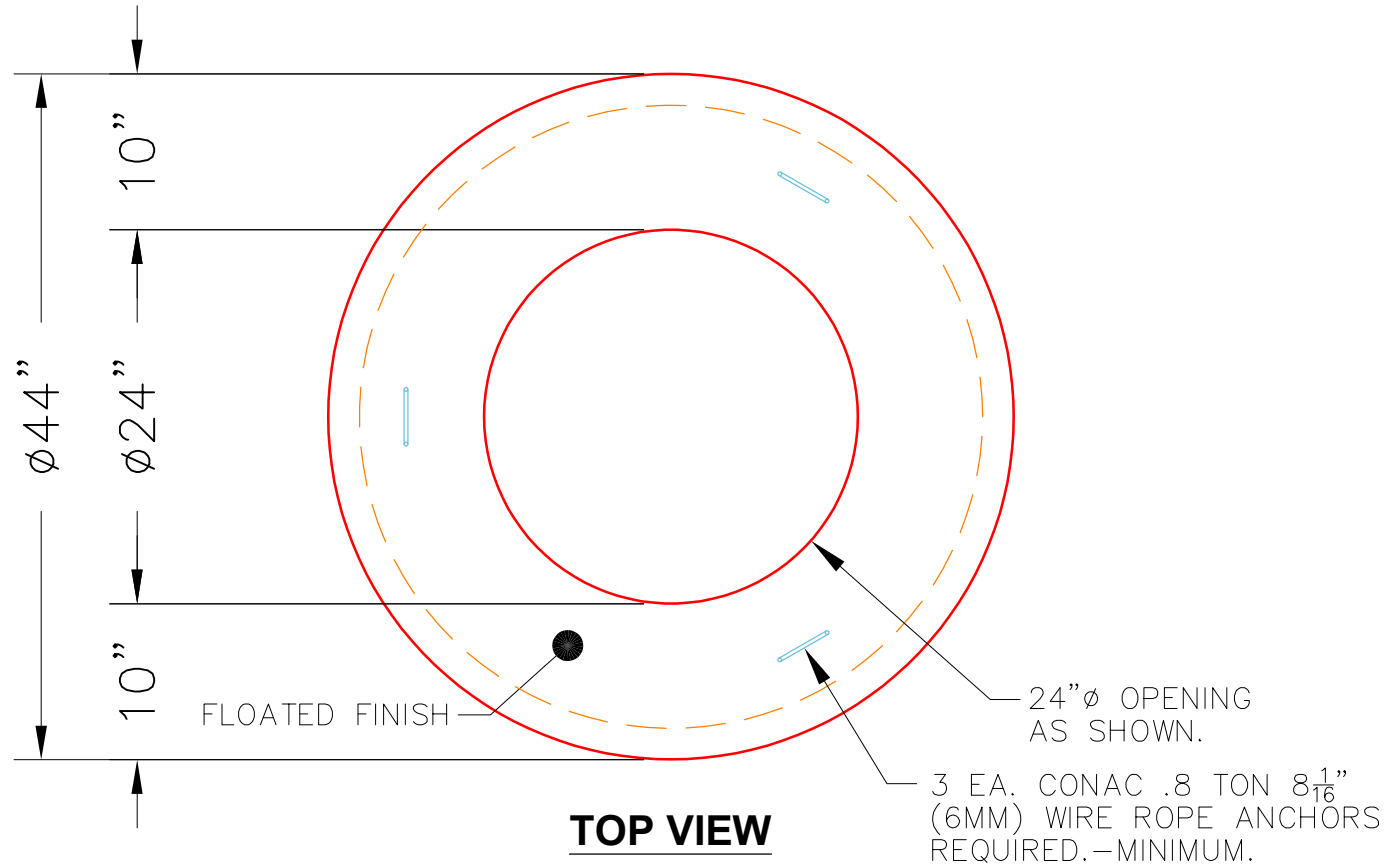

TOP VIEW

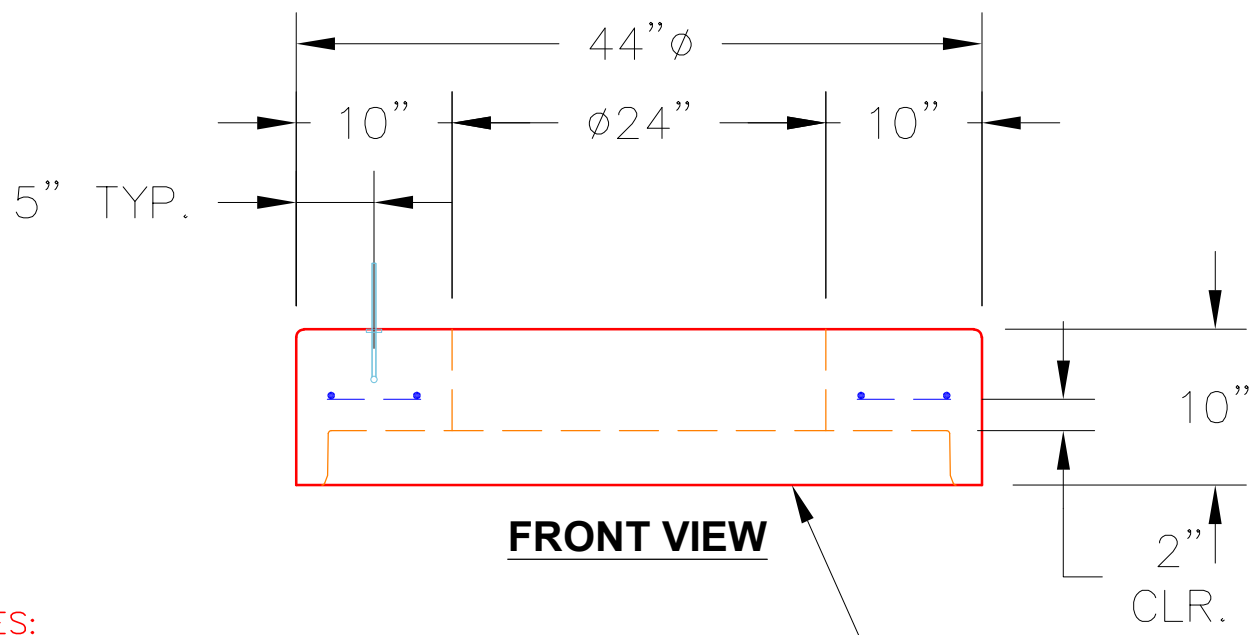

FRONT VIEW

NOTES:

1. MANUFACTURED TO ASTM C-478 (LATEST REVISION).
2. CONCRETE: 4,000 PSI AT 28 DAYS.
3. REINFORCING: #5 BAR @ 6" O.C. E.W. (GRADE 60).

STANDARD SINGLE OFFSET GROOVE JOINT REQUIRED

<p>PRODUCTION WORK ORDER</p>		<p>PRODUCT I.D.: MH036LD10</p>	<p>DESCRIPTION: 36" ϕ X 10" MH TOP SLAB 24" ϕ CONCENTRIC</p>	
	<p>QUALITY CONTROL CHECKLIST</p>	<p>PRODUCT VIEW: RIGHT SIDE UP</p>	<p>CUSTOMER: FRANKLIN BOE C/O LOUISVILLE PAVING</p>	
	<input type="checkbox"/> ALL DIMENSIONS CORRECT.	<p>PLANT: BEAVER DAM, KY.</p>	<p>PROJECT: ELKHORN RISER & MANHOLE</p>	
	<input type="checkbox"/> LIFTERS INSTALLED.	<p>WEIGHT: 896 LBS.</p>	<p>STRUCTURE: 3-54307A</p>	
	<input type="checkbox"/> HOLE LOCATION CORRECT.	<p>TOP SECTION JOINT: N/A</p>	<p>QUOTE/SALES ORDER NO: 25-4307</p>	
	<input type="checkbox"/> REINFORCING CORRECT.	<p>BASE SECTION JOINT: TONGUE</p>	<p>PC: J. JARVIS</p>	<p>DRAWING: J. COPPAGE</p>
	<input type="checkbox"/> FINISH ON SLAB SURFACE UNIFORM. <input type="checkbox"/> OUTSIDE TOP EDGE TROWELLED. <input type="checkbox"/> CORRECT JOINT INSTALLED.	<p>QC CHECK INITIALS:</p>	<p>DATE: 11/10/25</p>	<p>SCALE: NTS</p>