

Job Name: 25-4301 - 807890 1520 Hampton Street  
 Job Location: Nashville, TN  
 Contractor: Contech Engineering Solutions

Plant: Beaver Dam

10/29/2025 9:57:33 AM

Tech: J. Coppage

PC: T. Sekula



**Structure ID: 10-CS-6**

**P2 MH072RSVF**

**MH RISER Custom Ht**

- P4) 30" - CASTING HEIGHT - 4"
- P3) 72" - MH FLAT TOP SPEC. (30" ECC HOLE) - 15"
- P2) 72" - MH RISER Custom Ht - 49"
- P1) 72" - MH BASE - 36"
- 1) CVSTENCILING
- 1) PSASSEMBLY
- 2) 72" - Conseal CS-102 1.00"
- 2) Hole - 24

0 lb  
 4661 lb  
 6603 lb  
 9148 lb  
 0 lb  
 0 lb  
 0 lb  
 0 lb  
 -----  
 Structure Total: 20412 lb

**Structure Notes:**  
 (4" TALL CASTING PROVIDED BY OTHERS)  
  
 LIFTING ANCHORS TO BE INSTALLED ON THE OUTSIDE OF THE STRUCTURE  
  
 BASE TO BE MECHANICALLY ATTACHED TO THE CONTROL RISER  
  
 ICAST TO INSTALL THE INTERNALS  
  
 CONTECH'S LOGO AS WELL AS THE INLET AND OUTLET MUST BE STENCILED ONTO THE STRUCTURE

Rim: 477' Rim to Invert: 3.84' Slack: 2.08" Sump: 60" Step Position:

Position	Elev	Angle	Ext. (cw)	Pipe	Pipe OD	Connector	Hole	Horz Size	Up ( )	Offset
Invert 1	473.16'	270°	202.633"	18" HDPE	21.2"	Hole 24	24"	24.468"	16"	0"
Invert 2	473.16'	90°	67.544"	18" HDPE	21.2"	Hole 24	24"	24.468"	16"	0"
Invert 3										
Invert 4										
Invert 5										
Invert 6										
Invert 7										
Invert 8										

**RIGHT-SIDE UP VIEW (int. dimensions)**

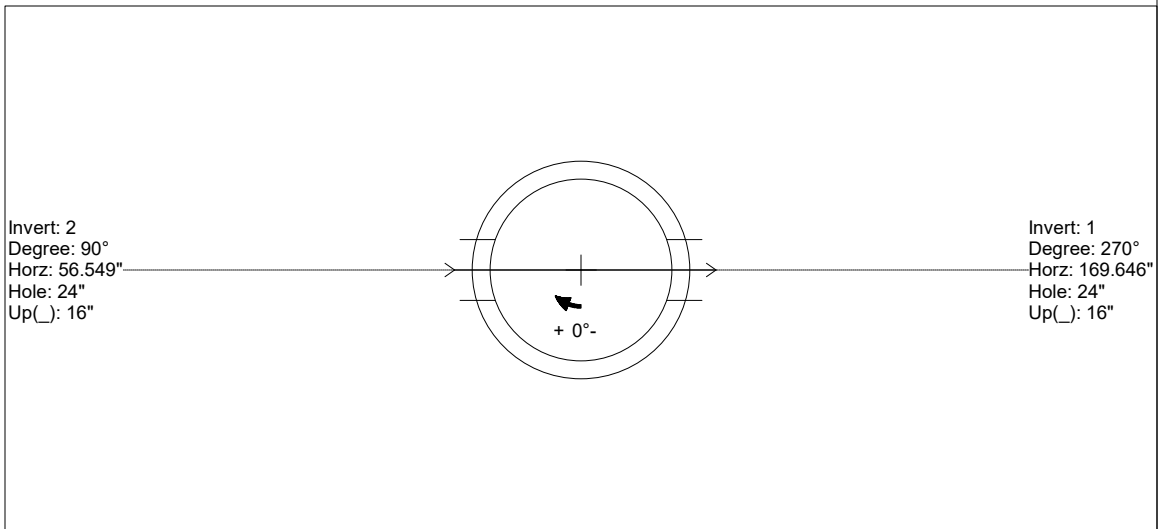
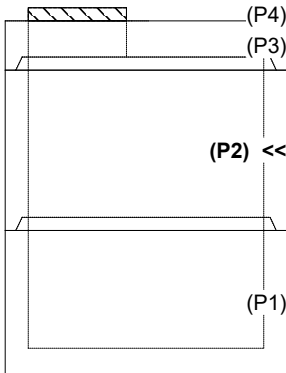

**INSIDE WALL DIMENSIONS**

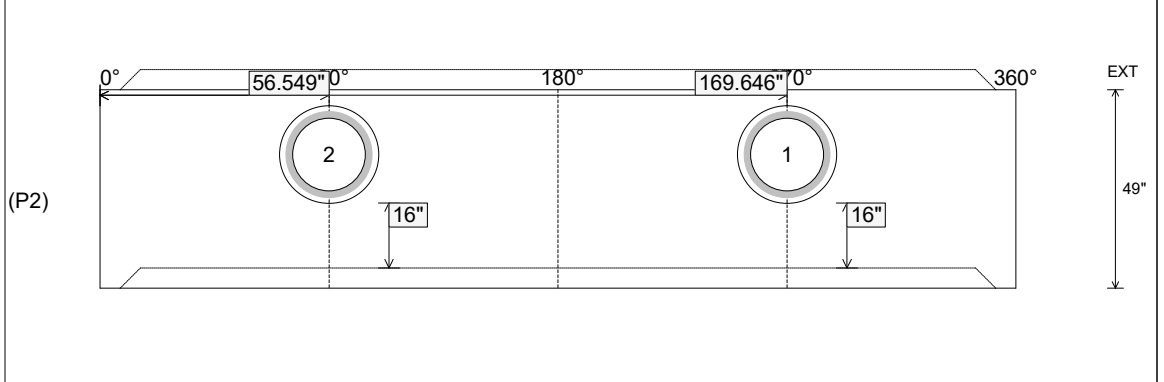

Coating (Int): Coating (Ext):	Seam Up: Tongue Seam Dn: Groove	Wall Thickness: 7" Floor Height: 0"	Height (Int): 49" Height (Ext): 49"	Weight (Net): 6603 lb Volume (Net): 1.69cu.yd
----------------------------------	------------------------------------	--	--	--