

Job Name: 25-4299 - Seneca High School
 Job Location: Louisville, KY
 Contractor: Dan Cristiani Excavating Co. Inc.

Plant: 100
 2/17/2026 10:39:14 AM

Tech: J. Horsley
 PC: J. Jarvis

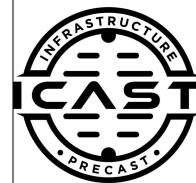

Structure ID: H9

P2 BX024024-06LD08S

CB FLAT TOP 8"W w/24" F/G F/F

- P3) 24" - CASTING HEIGHT - 0"
- P2) 24" x 24" - CB FLAT TOP 8"W w/24" F/G F/F - 6"
- P1) 24" x 24" - BOX BASE 8inW, 8inF, Variable Ht F/n - 19"
- 1) CASTING - HOE MCS-260B F/G
- 1) This Structure Includes a Cast-in Item - HOE MCS-260B Flange Side Up
- 1) 24" x 24" - Conseal CS-102 1.00"
- 1) Hole - 14
- 1) Hole - 6

0 lb
 750 lb
 2584 lb
 0 lb
 0 lb
 0 lb
 0 lb
 0 lb

 3334 lb

Structure Total:

Structure Notes:

1. PER LOUISVILLE MSD / ASTM C-913 SPECIFICATIONS
2. CONCRETE: 4,000 PSI AT 28 DAYS
3. REINFORCEMENT: #5 BAR @ 6" C.C. E.W. (GRADE 60) - 2" MIN. REBAR CLEARANCE (TYP)
4. HOE MCS-260B FRAME & GRATE SUPPLIED BY ICAST - FRAME TO BE CAST INTO FLAT LID FLANGE SIDE UP
5. LIFTERS: 2 EA. CONAC A-W ANCHORS FOR PLANT & FIELD HANDLING
6. TOP SURFACE TO RECEIVE LIGHT BRUSH FINISH

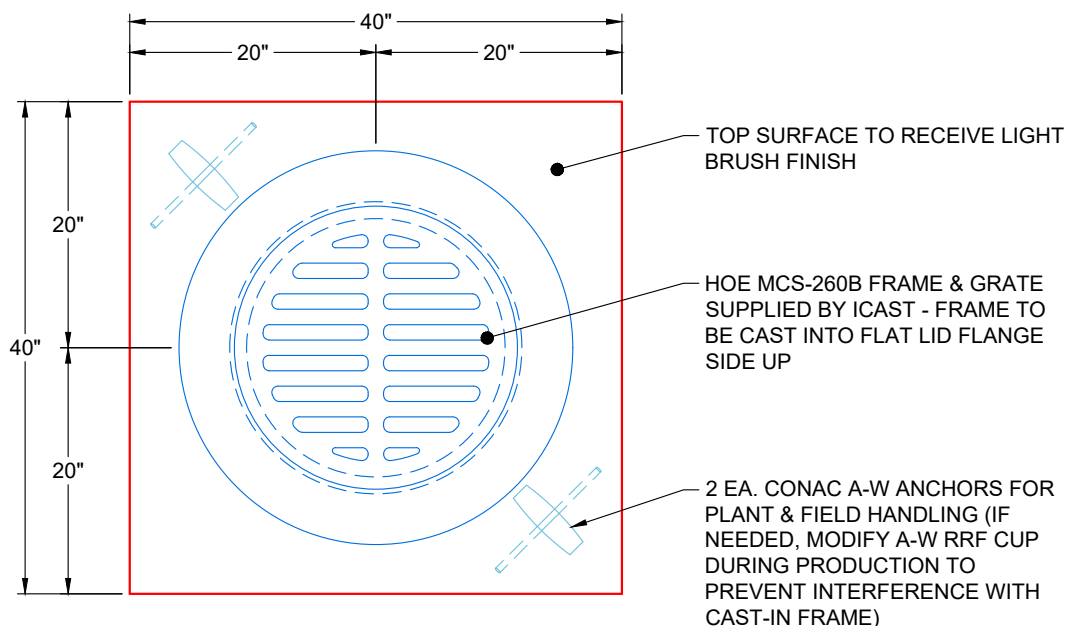

PLAN VIEW
(RIGHT SIDE UP)

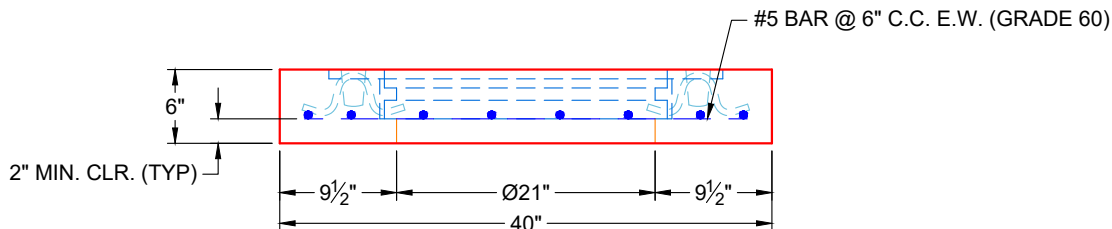

FRONT VIEW
(RIGHT SIDE UP)

Coating (Int):
 Coating (Ext):

Seam Up: Flat
 Seam Dn: Flat

Wall Thickness: 8"

Height (Ext): 6"

Weight (Net): 578 lb
 Volume (Net): 0.15cu.yd

Job Number:

25-4299

Job Name:

Dan Cristiani Excavating Co. Inc.

Structure:

H9

Note:

HOE MCS-260B Frame Supplied By
iCast To Be Cast Into Flat Lid
Flange Side Up