

Job Name: 25-4299 - Seneca High School  
 Job Location: Louisville, KY  
 Contractor: Dan Cristiani Excavating Co. Inc.

Plant: 100  
 2/17/2026 10:39:13 AM

Tech: J. Horsley  
 PC: J. Jarvis



**Structure ID: H8**

**P2 MH048LD07ECC**

**MH FLAT TOP w/ 24" ECC Hole F/F**

- P3) 24" - CASTING HEIGHT - 7"
- P2) 48" - MH FLAT TOP w/ 24" ECC Hole F/F - 7"
- P1) 48" - MH BASE Custom Ht F/n - 23"
- 1) 48" - Conseal CS-102 1.00"
- 1) Hole - 16
- 1) Hole - 14

0 lb  
 1286 lb  
 2786 lb  
 0 lb  
 0 lb  
 0 lb  
 \_\_\_\_\_  
 0 lb

Structure Total: 4072 lb

- Structure Notes:**
1. PER LOUISVILLE MSD / ASTM C-478 SPECIFICATIONS
  2. CONCRETE: 4,000 PSI AT 28 DAYS
  3. REINFORCEMENT: #4 BAR @ 10" C.C. E.W. (GRADE 60) - 2" MIN. REBAR CLEARANCE (TYP)
  4. HOE MC-420 FRAME & COVER "STORM LOU-MSD" SUPPLIED BY OTHERS
  5. LIFTERS: 3 EA. WRA016 CONAC WIRE ROPE ANCHORS FOR PLANT & FIELD HANDLING
  6. TOP SURFACE TO RECEIVE FLOATED FINISH

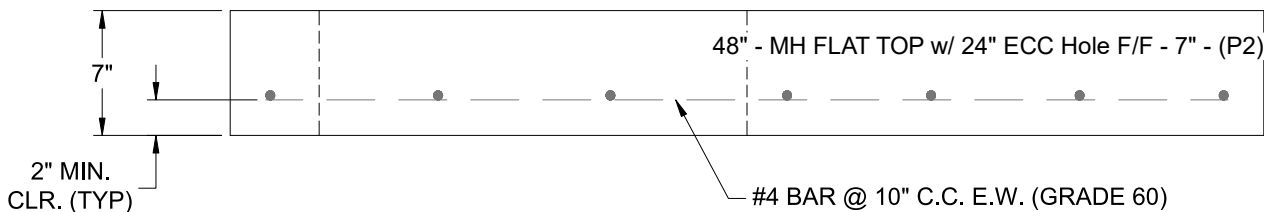
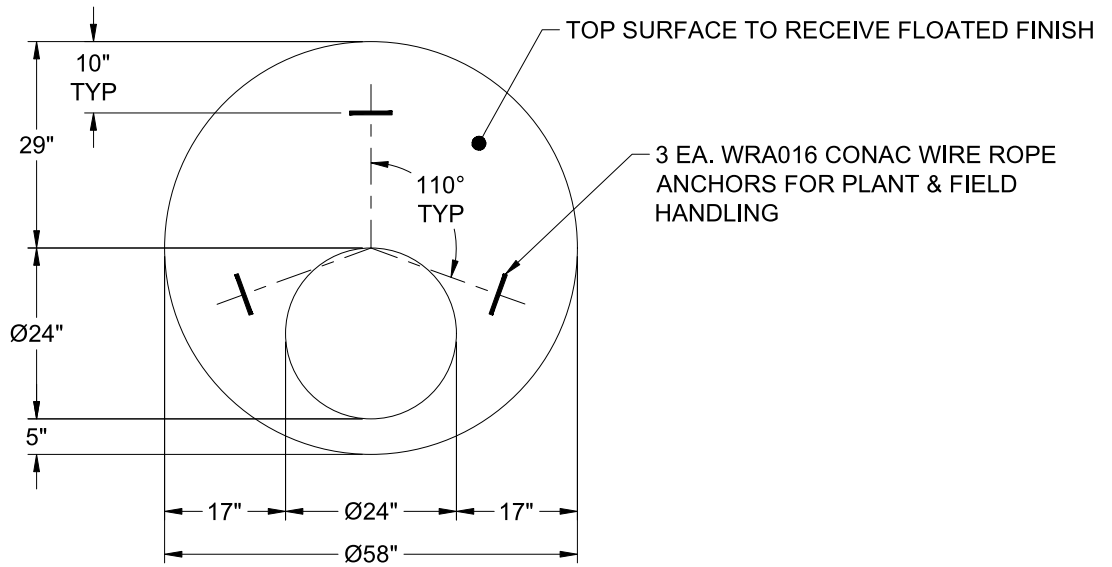

Coating (Int):  
 Coating (Ext):

Seam Up: Flat  
 Seam Dn: Flat

Wall Thickness: 5"

Height (Ext): 7"

Weight (Net): 1286 lb  
 Volume (Net): 0.33cu.yd