

Job Name: 25-4299 - Seneca High School
Job Location: Louisville, KY
Contractor: Dan Cristiani Excavating Co. Inc.

PC: J. Jarvis
 TECH: J. Horsley
 Plant: 100



Structure ID: **G6**
 Spec: MSD
 Type: CI DOUBLE
 Size: 48"

Rim: 484.15'
 Invert: 477.75'
 Rim to Invert: 6.4'

Sump: 1.9"
 Floor (Top): 477.592'
 Floor Height: 6"

Floor (Bot): 477.092'
 Overall Height: 7'
 Slack: 0.7"

Structure Notes:

- PER LOUISVILLE MSD / ASTM C-478 SPECIFICATIONS
- CONCRETE: 4,000 PSI AT 28 DAYS
- REINFORCEMENT:
 - FLAT LID: #6 BAR @ 4" C.C. E.W. (GRADE 60)
 - BASE: PER ASTM A615
- NO STORM INVERT
- STEPS AT 270 DEGREES
- HOE 470 FRAME, GRATE, & CURB HOOD SUPPLIED BY OTHERS

STRUCTURE SUMMARY:

- P3) 24" x 36" - CASTING HEIGHT - 6" 0 lb
 - P2) 48" - MH FLAT TOP w/24"x36" Hole LOU-MSD F/G - 12" 1790 lb
 - P1) 48" - MH BASE T/n - 60" 4890 lb
 - 1) 48" - Conseal CS-102 1.00" 0 lb
 - 1) 24" x 36" - Conseal CS-102 1.00" 0 lb
 - 2) Hole - 30 0 lb
 - 5) MH Step ML-10-TDS-NCR - 10" 0 lb
- Structure Total: 6680 lb

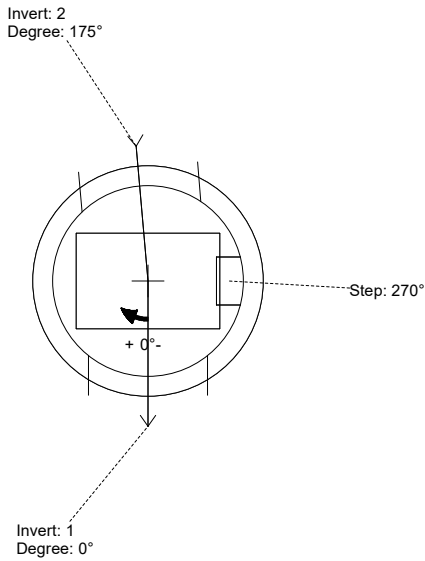

Position	Elev	Angle	Pipe	Pipe OD	Hole	Connector	Up (L)	Ref
Rim	484.15'							
Reducer								
Invert 1	477.75'	0°	24" HDPE	27.8"	30"	Hole 30	0"	P1
Invert 2	477.75'	175°	24" HDPE	27.8"	30"	Hole 30	0"	P1
Invert 3								
Invert 4								
Invert 5								
Invert 6								
Invert 7								
Invert 8								

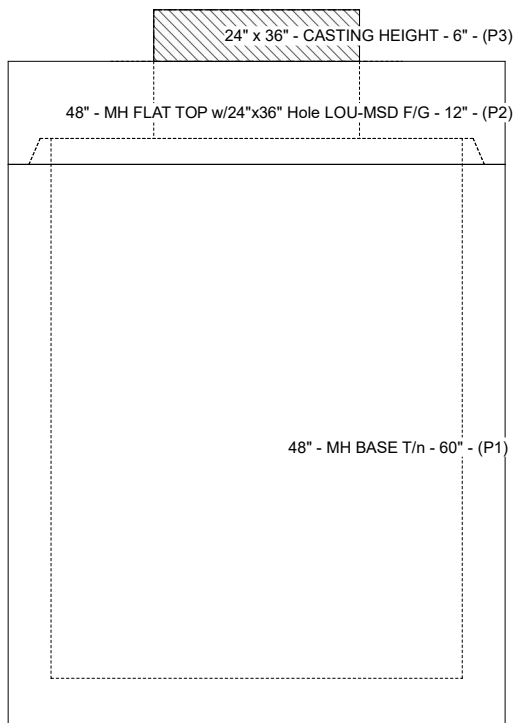

Cast (Int. Dim.) - Interior Dimensions

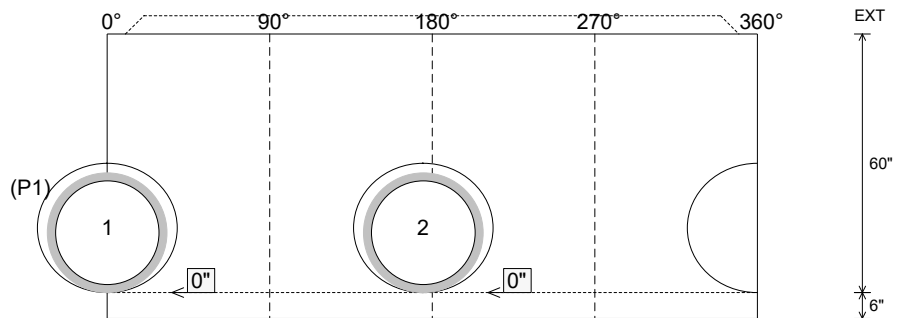

Submittal Drawing
 2/16/2026 1:45:52 PM

SUBMITTAL
 APPROVED BY: