

Structure ID: G2

P1 MH072BAVF

MH BASE Custom Ht T/n

P4) 24" - CASTING HEIGHT - 7" P3) 72" - MH FLAT LID w/24in ECC Hole F/G - 15" P2) 72" - MH RISER T/G - 24" P1) 72" - MH BASE Custom Ht T/n - 70" 2) 72" - Conseal CS-102 1.00" 1) Hole - 54 1) Hole - 24 1) Hole - 44 7) MH Step ML-10-TDS-NCR - 10"	0 lb 5098 lb 3499 lb 11392 lb 0 lb 0 lb 0 lb 0 lb 0 lb 0 lb Structure Total: 19988 lb
--	---

Structure Notes:

1. PER LOUISVILLE MSD / ASTM C-478 SPECIFICATIONS
2. CONCRETE: 4,000 PSI AT 28 DAYS
3. REINFORCEMENT: PER ASTM A615
4. NO STORM INVERT
5. STEPS AT 180 DEGREES
6. HOE MC-420 FRAME & COVER "STORM LOU-MSD" SUPPLIED BY OTHERS
7. INVERT 1 OFFSET 2" FROM CENTER

Rim: 485.2' Rim to Invert: 9.35' Slack: 0.7" Sump: 4.5" Step Position: 180°

Position	Elev	Angle	Ext. (cw)	Pipe	Pipe OD	Connector	Hole	Horz Size	Up ()	Offset
Invert 1	475.85'	0°	2.001"	42" RCP B WALL	51"	Hole 54	54"	61.353"	0"	2"
Invert 2	477.2'	90°	67.544"	18" HDPE	21.2"	Hole 24	24"	24.468"	19.1"	0"
Invert 3	475.85'	270°	202.633"	36" HDPE	41.7"	Hole 44	44"	47.337"	1.65"	0"
Invert 4										
Invert 5										
Invert 6										
Invert 7										
Invert 8										

RIGHT-SIDE UP VIEW (int. dimensions)

UPSIDE-DOWN VIEW (int. dimensions)

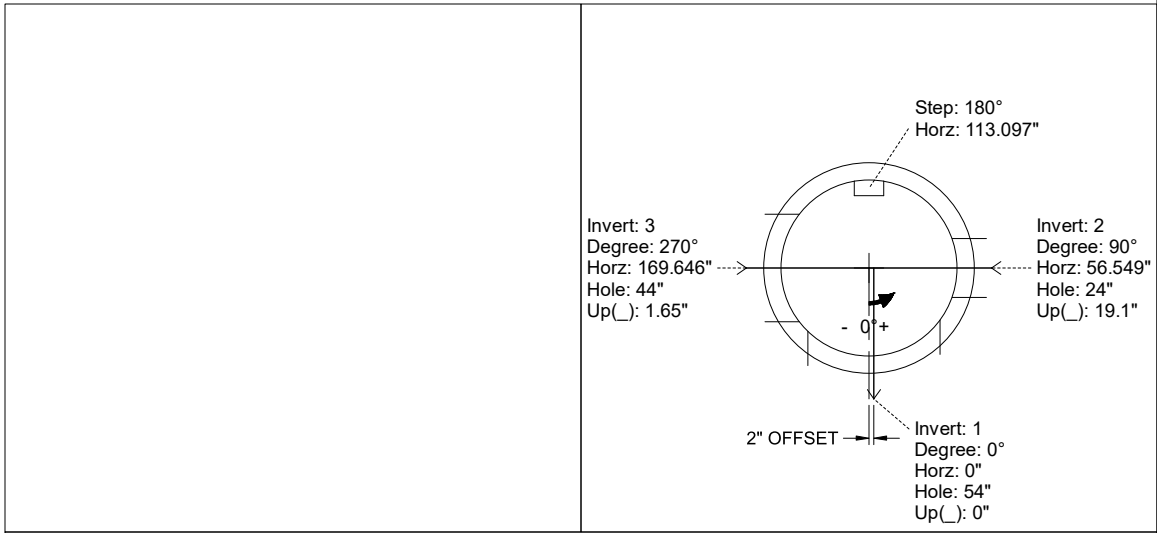
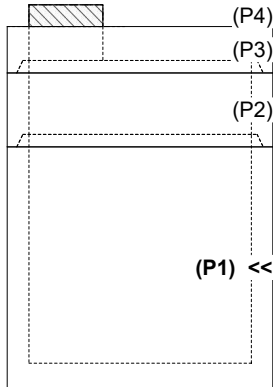

INSIDE WALL DIMENSIONS

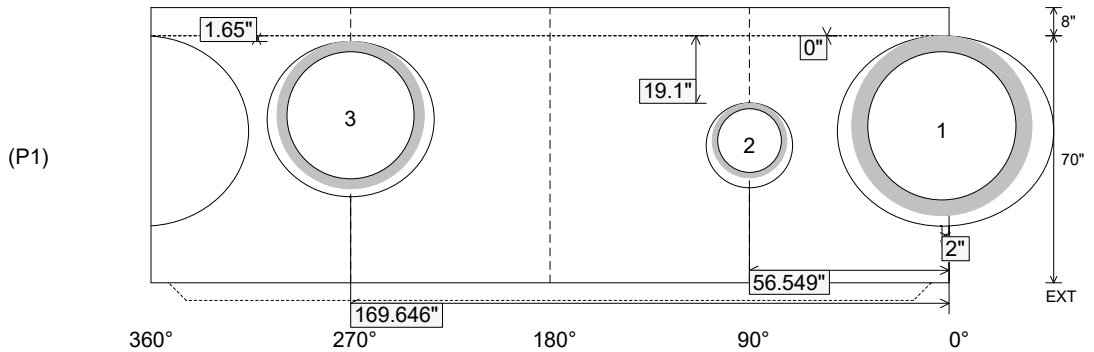

Coating (Int): Coating (Ext):	Seam Up: Tongue Seam Dn: n/a	Wall Thickness: 7" Floor Height: 8"	Height (Int): 70" Height (Ext): 78"	Weight (Net): 11392 lb Volume (Net): 2.91cu.yd
----------------------------------	---------------------------------	--	--	---