

Job Name: 25-4299 - Seneca High School	Plant: 100	Tech: J. Horsley	
Job Location: Louisville, KY	2/16/2026 3:51:28 PM	PC: J. Jarvis	
Contractor: Dan Cristiani Excavating Co. Inc.			

Structure ID: G11

P1 BX18180606VF

BOX BASE 6inW, 6inF, Variable Ht F/n

- P2) 18" x 18" - CASTING HEIGHT - 4"
- P1) 18" x 18" - BOX BASE 6inW, 6inF, Variable Ht F/n - 23"
- 1) 18" x 18" - Conseal CS-102 1.00"
- 2) Hole - 16

0 lb
1356 lb
0 lb
0 lb

Structure Total: 1356 lb

- Structure Notes:**
1. PER LOUISVILLE MSD / ASTM C-913 SPECIFICATIONS
 2. CONCRETE: 4,000 PSI AT 28 DAYS
 3. REINFORCEMENT: #5 BAR @ 12" C.C. E.W. (GRADE 60) - 2" MIN. REBAR CLEARANCE (TYP)
 4. NO STORM INVERT
 5. NO STEPS
 6. HOE 165-A FRAME & GRATE SUPPLIED BY OTHERS

Rim: 482' Rim to Invert: 2.33' Slack: 0.96" Sump: 0" Step Position:

Position	Elev	Angle	Ext. (cw)	Pipe	Pipe OD	Connector	Hole	Horz Size	Up ()	Offset
Invert 1	479.67'	0°	15"	12" HDPE	14.5"	Hole 16	16"	16"	-1.25"	0"
Invert 2	479.67'	160°	12.733"	12" HDPE	14.5"	Hole 16	16"	17.027"	-1.25"	3"
Invert 3										
Invert 4										
Invert 5										
Invert 6										
Invert 7										
Invert 8										

RIGHT-SIDE UP VIEW (int. dimensions)

UPSIDE-DOWN VIEW (int. dimensions)

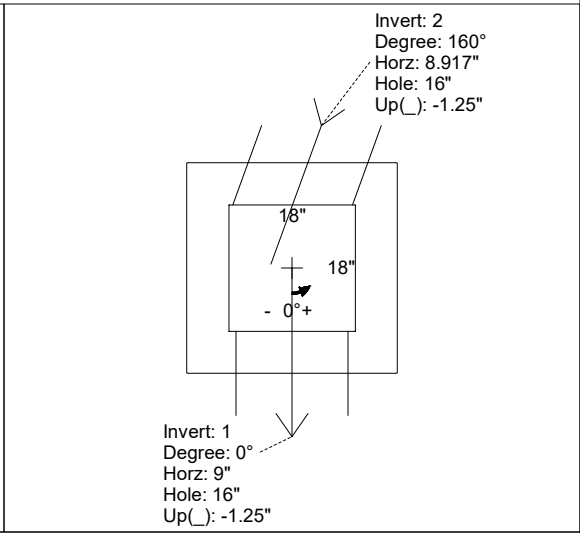
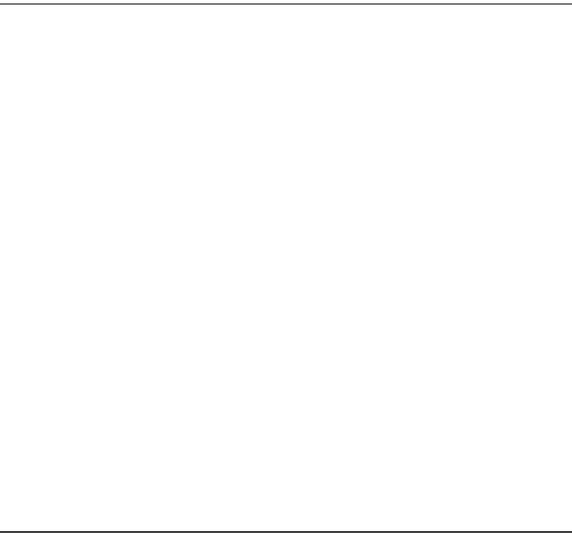
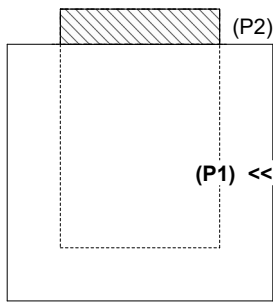

INSIDE WALL DIMENSIONS

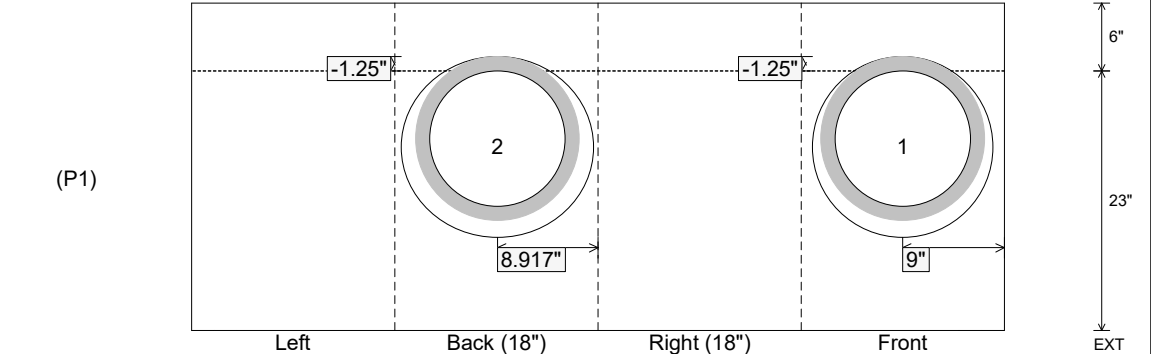

Coating (Int): Coating (Ext):	Seam Up: Flat Seam Dn: n/a	Wall Thickness: 6" Floor Height: 6"	Height (Int): 23" Height (Ext): 29"	Weight (Net): 1356 lb Volume (Net): 0.35cu.yd
----------------------------------	-------------------------------	--	--	--