

Job Name: 25-4299 - Seneca High School  
 Job Location: Louisville, KY  
 Contractor: Dan Cristiani Excavating Co. Inc.

Plant: 100  
 2/10/2026 8:24:12 AM

Tech: J. Horsley  
 PC: J. Jarvis



**Structure ID: F2**

**P1 MH048BA48**

**MH BASE T/n**

- P3) 24" x 24" - CASTING HEIGHT - 4"
- P2) 48" - MH FLAT TOP w/24"x24" Hole LOU-MSD F/G - 12"
- P1) 48" - MH BASE T/n - 48"
- 1) 48" - Conseal CS-102 1.00"
- 1) 24" x 24" - Conseal CS-102 1.00"
- 2) Hole - 20
- 4) MH Step ML-10-TDS-NCR - 10"

0 lb  
 1500 lb  
 4408 lb  
 0 lb  
 0 lb  
 0 lb  
 0 lb  
 -----  
 Structure Total: 5908 lb

- Structure Notes:**
1. PER LOUISVILLE MSD / ASTM C-478 SPECIFICATIONS
  2. CONCRETE: 4,000 PSI AT 28 DAYS
  3. REINFORCEMENT: PER ASTM A615
  4. NO STORM INVERT
  5. STEPS AT 265 DEGREES
  6. HOE 280T FRAME & GRATE SUPPLIED BY OTHERS

Rim: 482.5' Rim to Invert: 5.5' Slack: 2" Sump: 0" Step Position: 265°

Position	Elev	Angle	Ext. (cw)	Pipe	Pipe OD	Connector	Hole	Horz Size	Up ( )	Offset
Invert 1	477'	0°	0"	15" HDPE	17.6"	Hole 20	20"	20.629"	-1.3"	0"
Invert 2	477'	170°	86.045"	15" HDPE	17.6"	Hole 20	20"	20.629", 1.533"	-1.3"	0"
Invert 3										
Invert 4										
Invert 5										
Invert 6										
Invert 7										
Invert 8										

RIGHT-SIDE UP VIEW (int. dimensions)

UPSIDE-DOWN VIEW (int. dimensions)

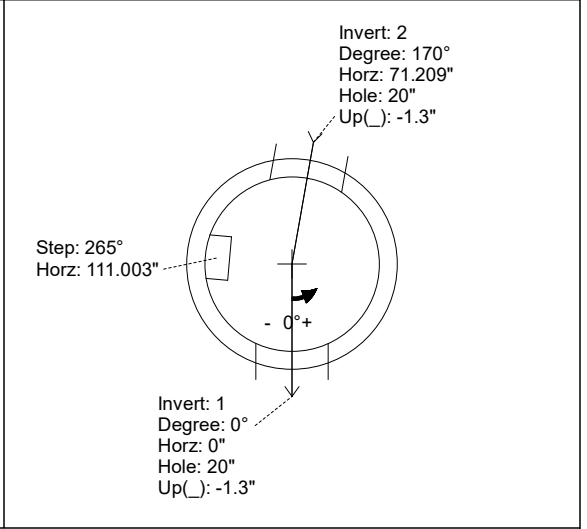
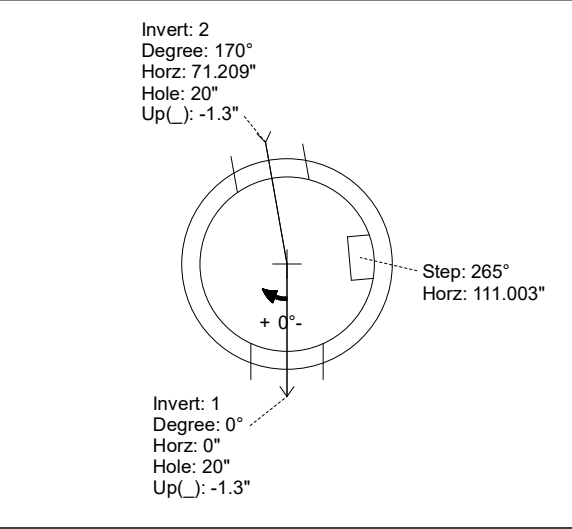
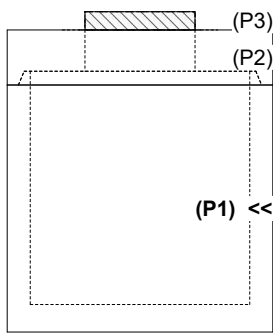

INSIDE WALL DIMENSIONS

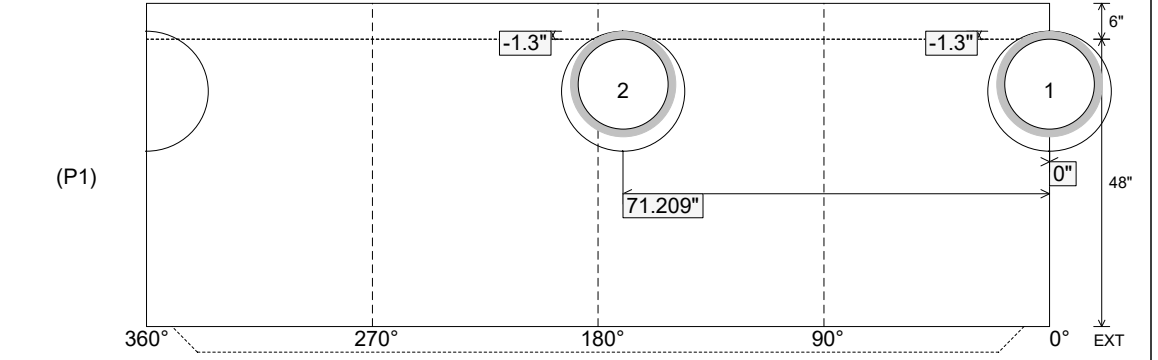

Coating (Int):  
 Coating (Ext):

Seam Up: Tongue  
 Seam Dn: n/a

Wall Thickness: 5"  
 Floor Height: 6"

Height (Int): 48"  
 Height (Ext): 54"

Weight (Net): 4408 lb  
 Volume (Net): 1.13cu.yd