

**Job Name: 25-4299 - Seneca High School**  
**Job Location: Louisville, KY**  
**Contractor: Dan Cristiani Excavating Co. Inc.**

PC: J. Jarvis  
 TECH: J. Horsley  
 Plant: 100



Structure ID: **A26**  
 Spec: MSD Rim: 485.2' Sump: 0" Floor (Bot): 482.583'  
 Type: CI DOUBLE Invert: 483.25' Floor (Top): 483.25' Overall Height: 2.583'  
 Size: 24" x 36" Rim to Invert: 1.95' Floor Height: 8" Slack: 0.4"

- Structure Notes:**
1. PER LOUISVILLE MSD / ASTM C-913 SPECIFICATIONS
  2. CONCRETE: 4,000 PSI AT 28 DAYS
  3. REINFORCEMENT: #5 BAR @ 12" C.C. E.W. (GRADE 60)
  4. NO STORM INVERT
  5. NO STEPS
  6. HOE 470 FRAME, GRATE, & CURB HOOD SUPPLIED BY OTHERS

**STRUCTURE SUMMARY:**

P2) 24" x 36" - CASTING HEIGHT - 6"  
 P1) 24" x 36" - BOX BASE 8inW, 8inF, Variable Ht F/n - 17"  
 1) 24" x 36" - Conseal CS-102 1.00"  
 1) Hole - 16

0 lb  
 2996 lb  
 0 lb  
 0 lb  
 -----  
 Structure Total: 2996 lb

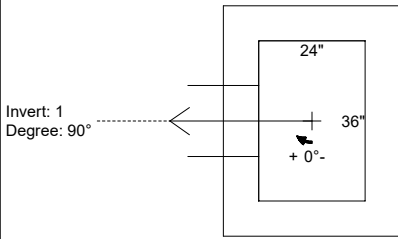

Position	Elev	Angle	Pipe	Pipe OD	Hole	Connector	Up ( )	Ref
Rim	485.2'							
Reducer								
Invert 1	483.25'	90°	12" HDPE	14.5"	16"	Hole 16	-1.25"	P1
Invert 2								
Invert 3								
Invert 4								
Invert 5								
Invert 6								
Invert 7								
Invert 8								

**Cast (Int. Dim.) - Interior Dimensions**

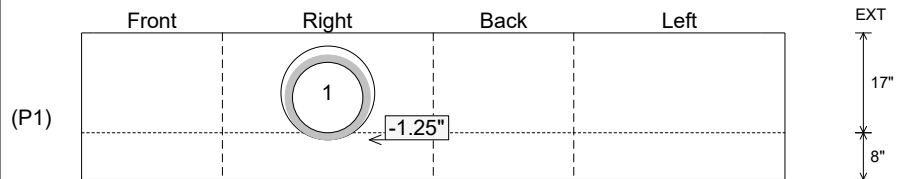
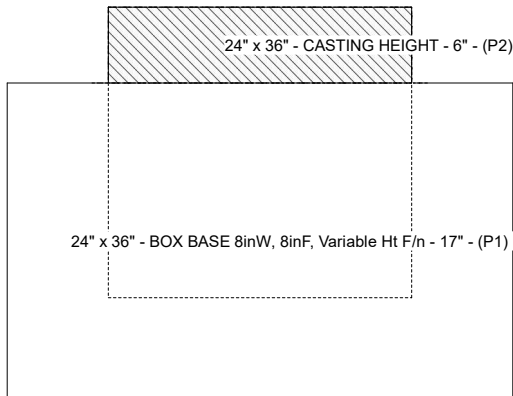

Submittal Drawing  
 2/13/2026 10:00:10 AM

SUBMITTAL  
 APPROVED BY: