

Job Name: 25-4299 - Seneca High School
 Job Location: Louisville, KY
 Contractor: Dan Cristiani Excavating Co. Inc.

Plant: 100
 2/10/2026 8:24:05 AM

Tech: J. Horsley
 PC: J. Jarvis



Structure ID: A13

P1 MH048BA36

MH BASE F/n

- P3) 24" x 36" - CASTING HEIGHT - 6"
- P2) 48" - MH FLAT TOP w/24"x36" Hole LOU-MSD F/F - 7"
- P1) 48" - MH BASE F/n - 36"
- 1) 48" - Conseal CS-102 1.00"
- 1) 24" x 36" - Conseal CS-102 1.00"
- 2) Hole - 30
- 3) MH Step ML-10-TDS-NCR - 10"

0 lb
 1044 lb
 3213 lb
 0 lb
 0 lb
 0 lb
 0 lb

 4257 lb

Structure Total:

- Structure Notes:**
1. PER LOUISVILLE MSD / ASTM C-478 SPECIFICATIONS
 2. CONCRETE: 4,000 PSI AT 28 DAYS
 3. REINFORCEMENT: PER ASTM A615
 4. NO STORM INVERT
 5. STEPS AT 250.5 DEGREES
 6. HOE 470 FRAME, GRATE, & CURB HOOD SUPPLIED BY OTHERS

Rim: 486' Rim to Invert: 3.95' Slack: 0.3" Sump: 1.9" Step Position: 250.5°

Position	Elev	Angle	Ext. (cw)	Pipe	Pipe OD	Connector	Hole	Horz Size	Up ()	Offset
Invert 1	482.05'	0°	0"	24" HDPE	27.8"	Hole 30	30"	32.406"	0"	0"
Invert 2	482.05'	141°	71.367"	24" HDPE	27.8"	Hole 30	30"	32.406"	0"	0"
Invert 3										
Invert 4										
Invert 5										
Invert 6										
Invert 7										
Invert 8										

RIGHT-SIDE UP VIEW (int. dimensions)

UPSIDE-DOWN VIEW (int. dimenions)

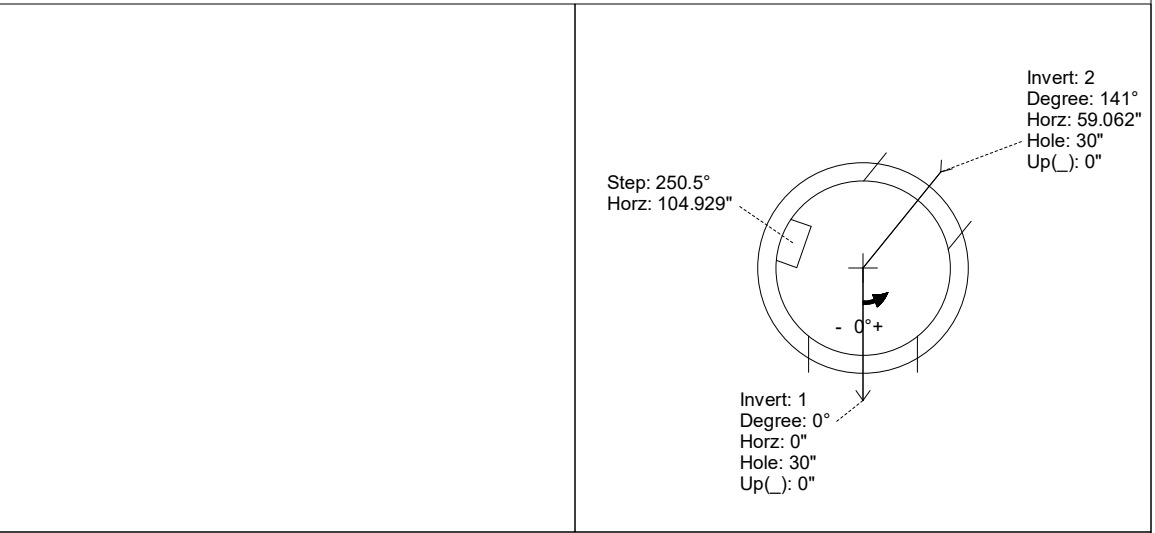
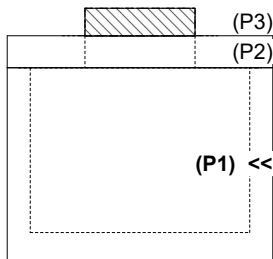

INSIDE WALL DIMENSIONS

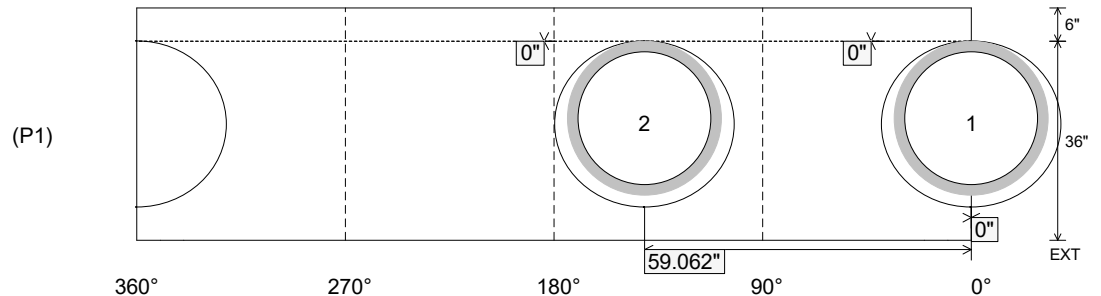

Coating (Int):
 Coating (Ext):

Seam Up: Flat
 Seam Dn: n/a

Wall Thickness: 5"
 Floor Height: 6"

Height (Int): 36"
 Height (Ext): 42"

Weight (Net): 3213 lb
 Volume (Net): 0.82cu.yd