

Job Name: 25-4299 - Seneca High School  
 Job Location: Louisville, KY  
 Contractor: Dan Cristiani Excavating Co. Inc.

Plant: 100  
 2/10/2026 8:29:06 AM

Tech: J. Horsley  
 PC: J. Jarvis



**Structure ID: 6+35.95**

**P3 GR3**

**GRADE RING F/F**

- P4) 24" - CASTING HEIGHT - 7"
- P3) 24" - GRADE RING F/F - 3"
- P2) 48" - ECC CONE w/ 24" HOLE F/G - 24"
- P1) 48" - MH BASE T/n - 24"
- 1) 48" - MH INVERT CHANNEL - FULL HEIGHT
- 1) JOINT WRAP - 0.065"x6"x50' CONSEAL CS212
- 1) JOINT WRAP PRIMER - CONSEAL CS-75 (1 gal.)
- 1) Chimney Seal - Cretex Chimney Seal
- 1) 48" - Conseal CS-102 1.00" (Double)
- 2) PSX - 16Y NYLO
- 3) MH Step ML-10-TDS-NCR - 10"

0 lb  
 202 lb  
 1550 lb  
 2835 lb  
 1440 lb  
 0 lb  
 0 lb  
 10 lb  
 0 lb  
 16 lb  
 0 lb  
 \_\_\_\_\_  
 Structure Total: 6054 lb

Structure Notes:  
 1. PER ASTM C-478 SPECIFICATIONS  
 2. CONCRETE: 4,000 PSI AT 28 DAYS  
 3. REINFORCEMENT: (1) #3 HOOP CENTERED (GRADE 60)

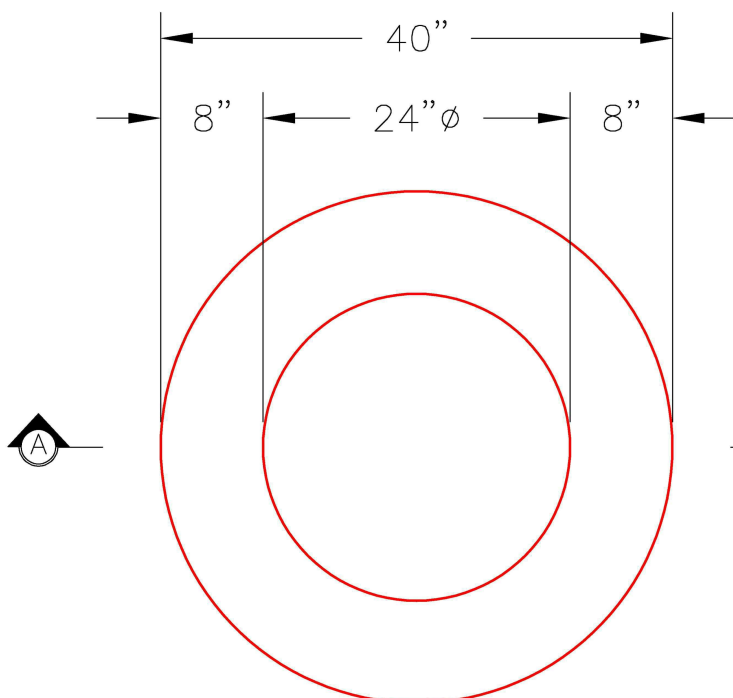

**PLAN VIEW**

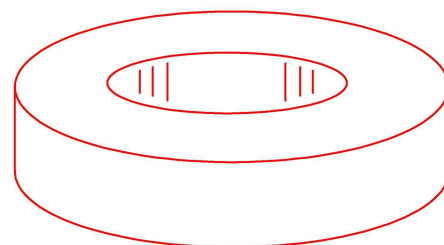

**ISOMETRIC VIEW**

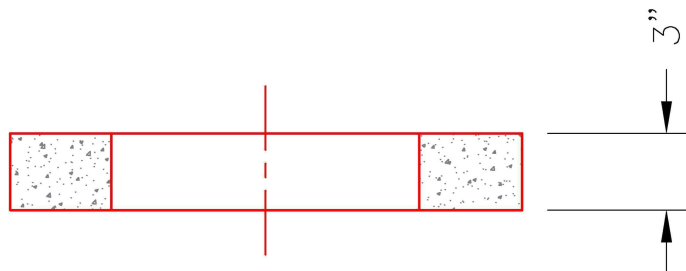

**SECTION A-A**

Coating (Int):  
 Coating (Ext):

Seam Up: Flat  
 Seam Dn: Flat

Wall Thickness: 8"

Height (Ext): 3"

Weight (Net): 202 lb  
 Volume (Net): 0.05cu.yd