

Job Name: 25-4285 - KYTC Campbell Co (254026)  
 Job Location: Alexandria, KY  
 Contractor: Eaton Asphalt

Plant: 100

Tech: Jared - F

3/20/2026 3:24:00 PM

PC: E. Bradley



**Structure ID: 10921**

**P1 BX3648-08BAVF**

**BOX BASE 8inW, 8inF, Variable Ht F/n**

- P2) 36" x 48" - P.I.P. - BY OTHERS - 8"
- P1) 36" x 48" - BOX BASE 8inW, 8inF, Variable Ht F/n - 38"
- 1) CASTING - HOE KY-460 SET (DBI 5D)
- 1) 36" x 48" - Conseal CS-102 1.00"
- 1) Hole - 30
- 1) Hole - 24

0 lb  
 6558 lb  
 460 lb  
 0 lb  
 0 lb  
 -----  
 Structure Total: 7018 lb

**Structure Notes:**  
**\*\*KYTC STATE PROJECT\*\***  
 1. KYTC DBI TYPE 5D  
 2. PER ASTM C913  
 3. CASTING BY ICAST (HOE KY-460 SET (DBI 5D))  
 4. STUB #5 BARS 20" OUT TOP OF WALLS (SPA@12"C/C)

Rim: 656.39' Rim to Invert: 3.91' Slack: 0.92' Sump: 0" Step Position:

Position	Elev	Angle	Ext. (cw)	Pipe	Pipe OD	Connector	Hole	Horz Size	Up ( )	Offset
Invert 1	652.48'	0°	26"	24" HDPE	27.8"	Hole 30	30"	30"	-3"	0"
Invert 2	652.48'	270°	32"	18" HDPE	21.2"	Hole 24	24"	24"	-3"	0"
Invert 3										
Invert 4										
Invert 5										
Invert 6										
Invert 7										
Invert 8										

RIGHT-SIDE UP VIEW (int. dimensions)

UPSIDE-DOWN VIEW (int. dimensions)

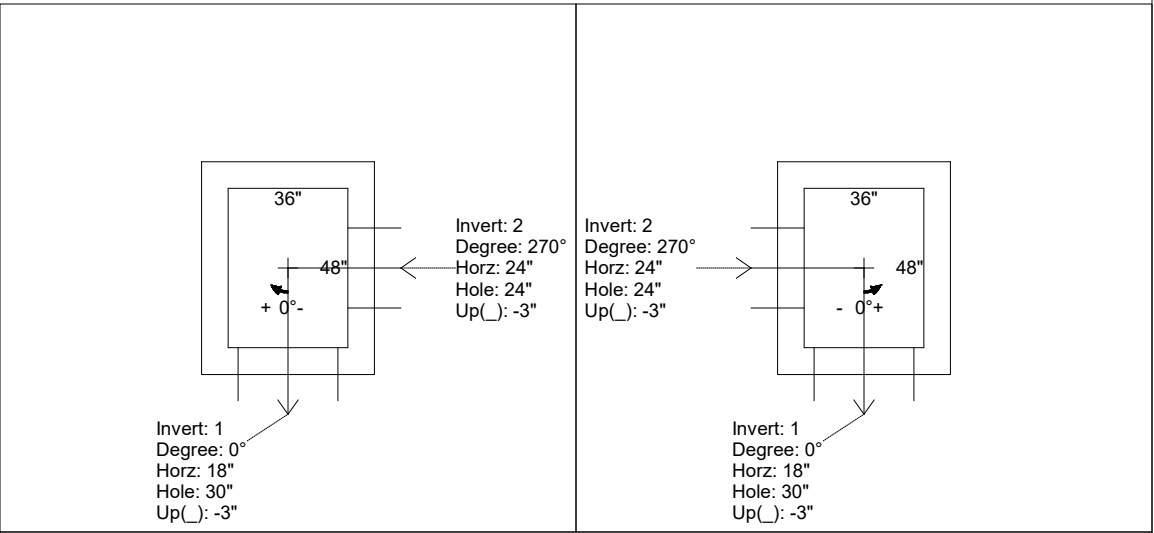
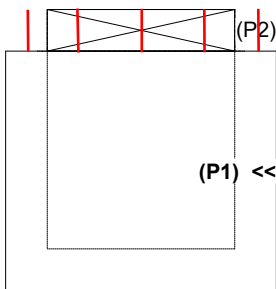

INSIDE WALL DIMENSIONS

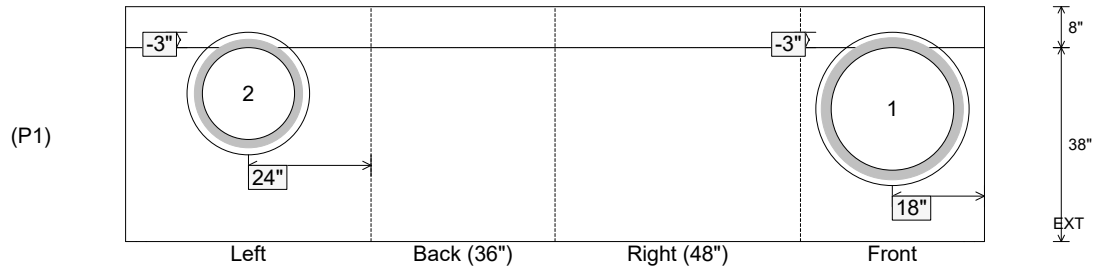

Coating (Int):  
 Coating (Ext):

Seam Up: Flat  
 Seam Dn: n/a

Wall Thickness: 8"  
 Floor Height: 8"

Height (Int): 38"  
 Height (Ext): 46"

Weight (Net): 6558 lb  
 Volume (Net): 1.68cu.yd