

Job Name: 25-4272B Chestnut Street Utility Rehab
 Job Location: Evansville, IN
 Contractor: Bowen Engineering Corporation

Plant: Beaver Dam
 1/14/2026 11:58:01 AM

Tech: J. Coppage
 PC: A. Chambers



Structure ID: 1015

P1 CVBASE-BS

BOX BASE 10inW, 12inF, Variable Ht w/ Xypex Bio-San C-500

P6) 72" x 72" - HATCH (CAST FLUSH) - 3"	100 lb
P5) 96" x 96" - BX FLAT LID 10inW w/72"x72" HATCH w/ Xypex Bio-San C-500 - 12"	8329 lb
P4) 96" x 96" - BOX RISER 10inW, Variable Ht w/ Xypex Bio-San C-500 - 62"	22059 lb
P3) 96" x 96" - BOX RISER 10inW, Variable Ht w/ Xypex Bio-San C-500 - 58"	20636 lb
P2) 96" x 96" - BOX RISER 10inW, Variable Ht w/ Xypex Bio-San C-500 - 94"	32389 lb
P1) 96" x 96" - BOX BASE 10inW, 12inF, Variable Ht w/ Xypex Bio-San C-500 - 94"	42248 lb
1) This Structure Includes a Cast-in Item	0 lb
1) HATCH (Alum.) - HALLIDAY H2C 72"x72"	235 lb
4) 96" x 96" - Conseal CS-102 1.00"	0 lb
1) 72" x 72" - Conseal CS-102 1.00"	0 lb
2) Hole - 60	0 lb
1) Hole - 40	0 lb
Structure Total:	125997 lb

Structure Notes:

- PER ASTM C913 SPECIFICATIONS.
- CONCRETE = 4,500 PSI AT 28 DAYS.
- HALLIDAY 72" X 72" H2C HATCH BY ICAST.
- HATCH TO BE CAST INTO THE TOP SLAB.
- REINFORCING PER ASTM A615 (GRADE 60).
 TOP SLAB - #6 @ 8" O.C. E.W. TOP & BTM MAT.
 WALLS/FLOOR - #5 @ 8" O.C. E.W. DBL MAT.
 ADDITIONAL REINFORCEMENT IN CORNERS AND AROUND OPENINGS.

FIRST POUR DRAWING

Rim: 379.5' Rim to Invert: 26.58' Slack: 0.11" Sump: 1.15" Step Position:

Position	Elev	Angle	Ext. (cw)	Pipe	Pipe OD	Connector	Hole	Horz Size	Up ()	Offset
Invert 1	352.92'	90°	58"	54" HDPE (DUROMAXX)	55.5"	Hole 60	60"	60"	0"	0"
Invert 2	353.82'	270°	58"	54" HDPE (DUROMAXX)	55.5"	Hole 60	60"	60"	10.8"	0"
Invert 3										
Invert 4										
Invert 5										
Invert 6										
Invert 7										
Invert 8										

RIGHT-SIDE UP VIEW (int. dimensions)

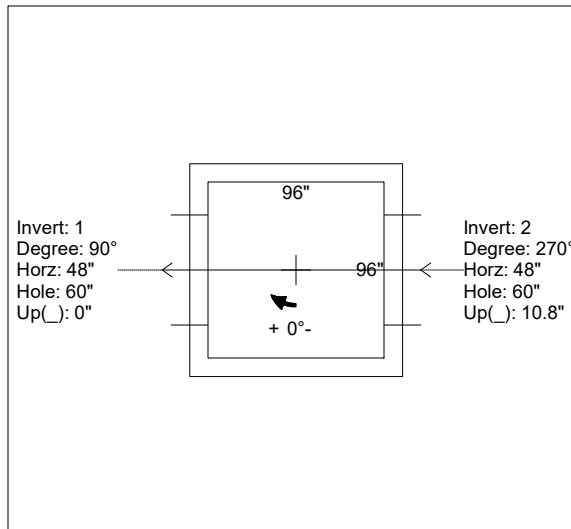
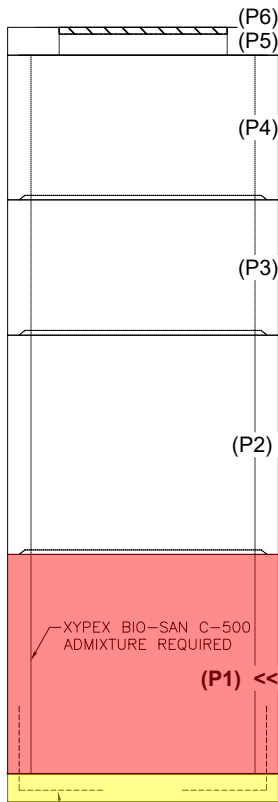

WEIGHTS:

- FIRST POUR - 13,549 LBS.**
- SECOND POUR - 28,699 LBS.**
- TOTAL - 42,248 LBS.**

INSIDE WALL DIMENSIONS

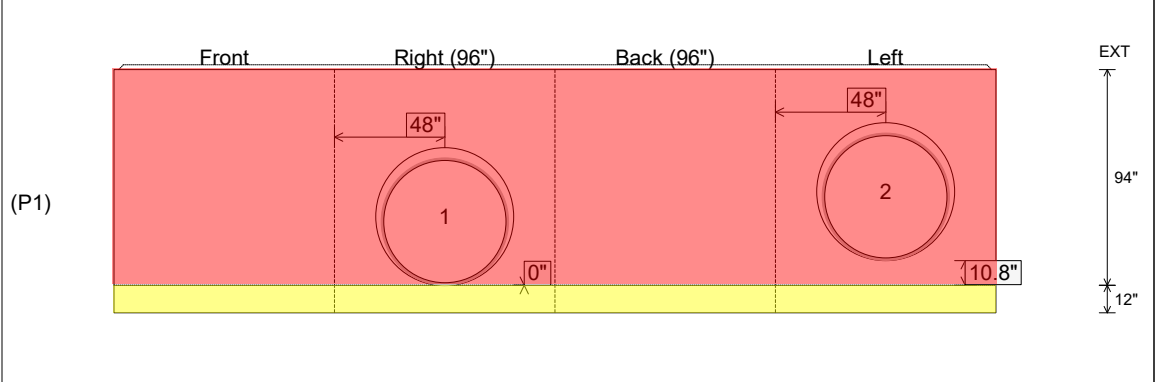

Coating (Int): Coating (Ext):	Seam Up: Tongue Seam Dn: n/a	Wall Thickness: 10" Floor Height: 12"	Height (Int): 94" Height (Ext): 106"	Weight (Net): 42248 lb Volume (Net): 10.79cu.yd
----------------------------------	---------------------------------	--	---	--

Job Name: 25-4272B Chestnut Street Utility Rehab
 Job Location: Evansville, IN
 Contractor: Bowen Engineering Corporation

Plant: Beaver Dam
 1/14/2026 11:58:01 AM

Tech: J. Coppage
 PC: A. Chambers



Structure ID: 1015

P1 CVBASE-BS

BOX BASE 10inW, 12inF, Variable Ht w/ Xypex Bio-San C-500

P6) 72" x 72" - HATCH (CAST FLUSH) - 3"	100 lb
P5) 96" x 96" - BX FLAT LID 10inW w/72"x72" HATCH w/ Xypex Bio-San C-500 - 12"	8329 lb
P4) 96" x 96" - BOX RISER 10inW, Variable Ht w/ Xypex Bio-San C-500 - 62"	22059 lb
P3) 96" x 96" - BOX RISER 10inW, Variable Ht w/ Xypex Bio-San C-500 - 58"	20636 lb
P2) 96" x 96" - BOX RISER 10inW, Variable Ht w/ Xypex Bio-San C-500 - 94"	32389 lb
P1) 96" x 96" - BOX BASE 10inW, 12inF, Variable Ht w/ Xypex Bio-San C-500 - 94"	42248 lb
1) This Structure Includes a Cast-in Item	0 lb
1) HATCH (Alum.) - HALLIDAY H2C 72"x72"	235 lb
4) 96" x 96" - Conseal CS-102 1.00"	0 lb
1) 72" x 72" - Conseal CS-102 1.00"	0 lb
2) Hole - 60	0 lb
1) Hole - 40	0 lb
Structure Total:	125997 lb

Structure Notes:

- PER ASTM C913 SPECIFICATIONS.
- CONCRETE = 4,500 PSI AT 28 DAYS.
- HALLIDAY 72" X 72" H2C HATCH BY ICAST.
- HATCH TO BE CAST INTO THE TOP SLAB.
- REINFORCING PER ASTM A615 (GRADE 60).
 TOP SLAB - #6 @ 8" O.C. E.W. TOP & BTM MAT.
 WALLS/FLOOR - #5 @ 8" O.C. E.W. DBL MAT.
 ADDITIONAL REINFORCEMENT IN CORNERS AND AROUND OPENINGS.

SECOND POUR DRAWING

Rim: 379.5' Rim to Invert: 26.58' Slack: 0.11" Sump: 1.15" Step Position:

Position	Elev	Angle	Ext. (cw)	Pipe	Pipe OD	Connector	Hole	Horz Size	Up ()	Offset
Invert 1	352.92'	90°	58"	54" HDPE (DUROMAXX)	55.5"	Hole 60	60"	60"	0"	0"
Invert 2	353.82'	270°	58"	54" HDPE (DUROMAXX)	55.5"	Hole 60	60"	60"	10.8"	0"
Invert 3										
Invert 4										
Invert 5										
Invert 6										
Invert 7										
Invert 8										

RIGHT-SIDE UP VIEW (int. dimensions)

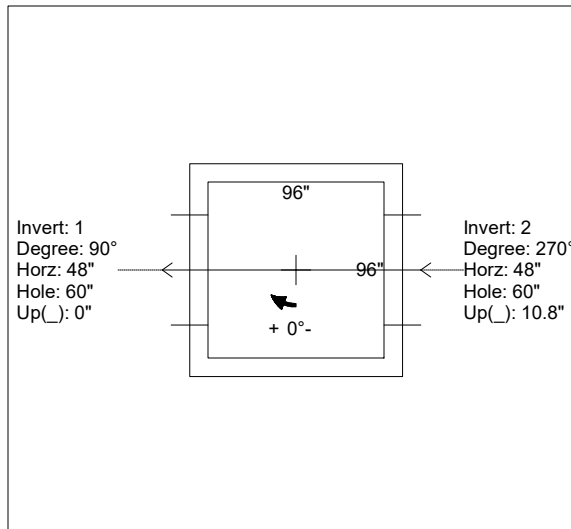
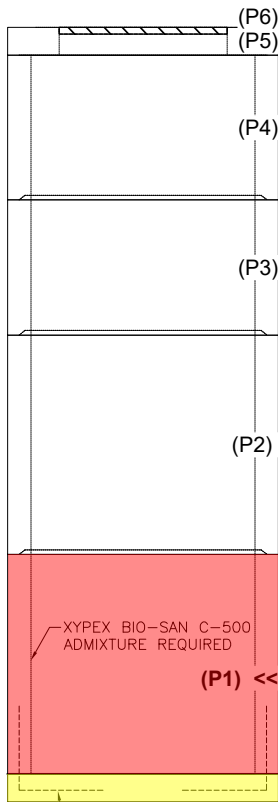

WEIGHTS:

- FIRST POUR - 13,549 LBS.**
- SECOND POUR - 28,699 LBS.**
- TOTAL - 42,248 LBS.**

INSIDE WALL DIMENSIONS

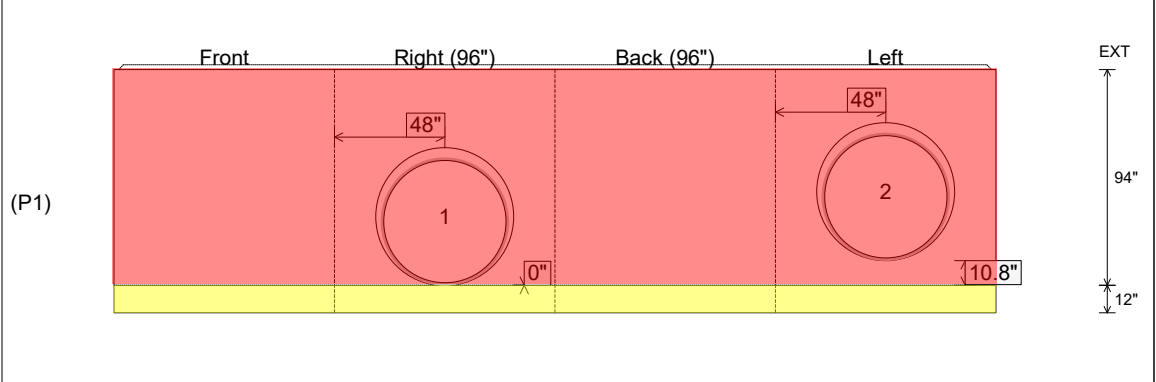

Coating (Int): Coating (Ext):	Seam Up: Tongue Seam Dn: n/a	Wall Thickness: 10" Floor Height: 12"	Height (Int): 94" Height (Ext): 106"	Weight (Net): 42248 lb Volume (Net): 10.79cu.yd
----------------------------------	---------------------------------	--	---	--