

**PLAN VIEW**

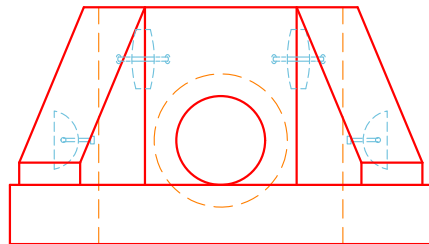

**FRONT VIEW**

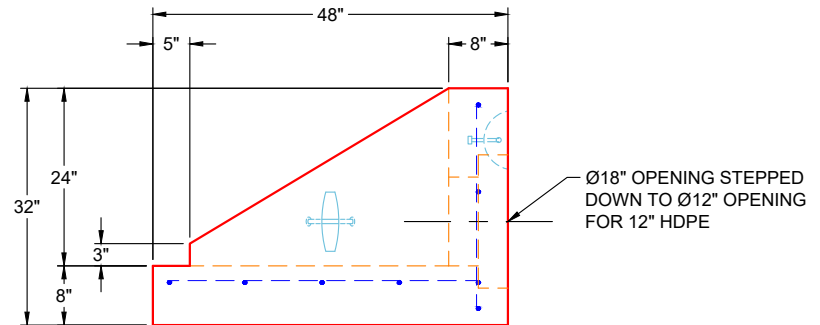

**SIDE VIEW**

**GENERAL NOTES:**

1. CONCRETE: 4,500 PSI AT 28 DAYS
2. REINFORCING: #4 BAR @ 12" C.C. E.W. (GRADE 60)
3. PIPE AND LIFTING ANCHOR POCKETS TO BE GROUTED WITH NON-SHRINK GROUT
4. 3/4" CHAMBER ON ALL EXPOSED EDGES
5. WEIGHT: 2,545 LBS

**REVISION INFORMATION**

REV.	DATE:	NO REVISIONS TO DATE



SUBMITTAL DRAWING: 12" SF HW FLAT BOTTOM		
CUSTOMER: SCOTT & RITTER		
PROJECT: THE PROFESSIONAL PARK LOTS 5 & 6		
STRUCTURE: ST A1		
QUOTE/SALES ORDER NO: 25-4268		
PC: C. GOFF	DRAWN BY: K. CARDWELL	
DATE: 10/26/25	SCALE: NTS	PG. 1 OF 1