

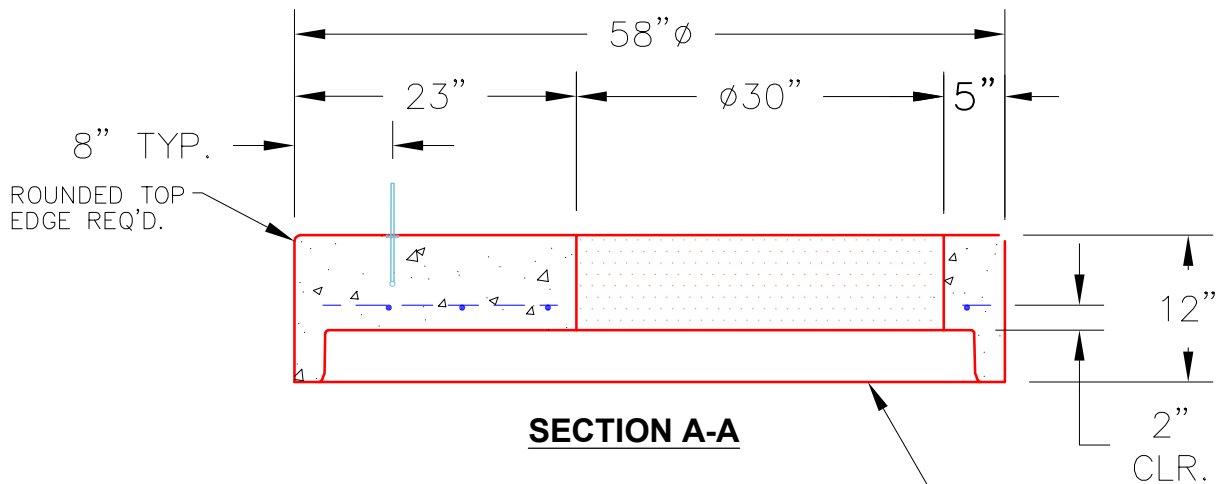

THIS DRAWING IS INTENDED TO BE PRINTED IN COLOR.

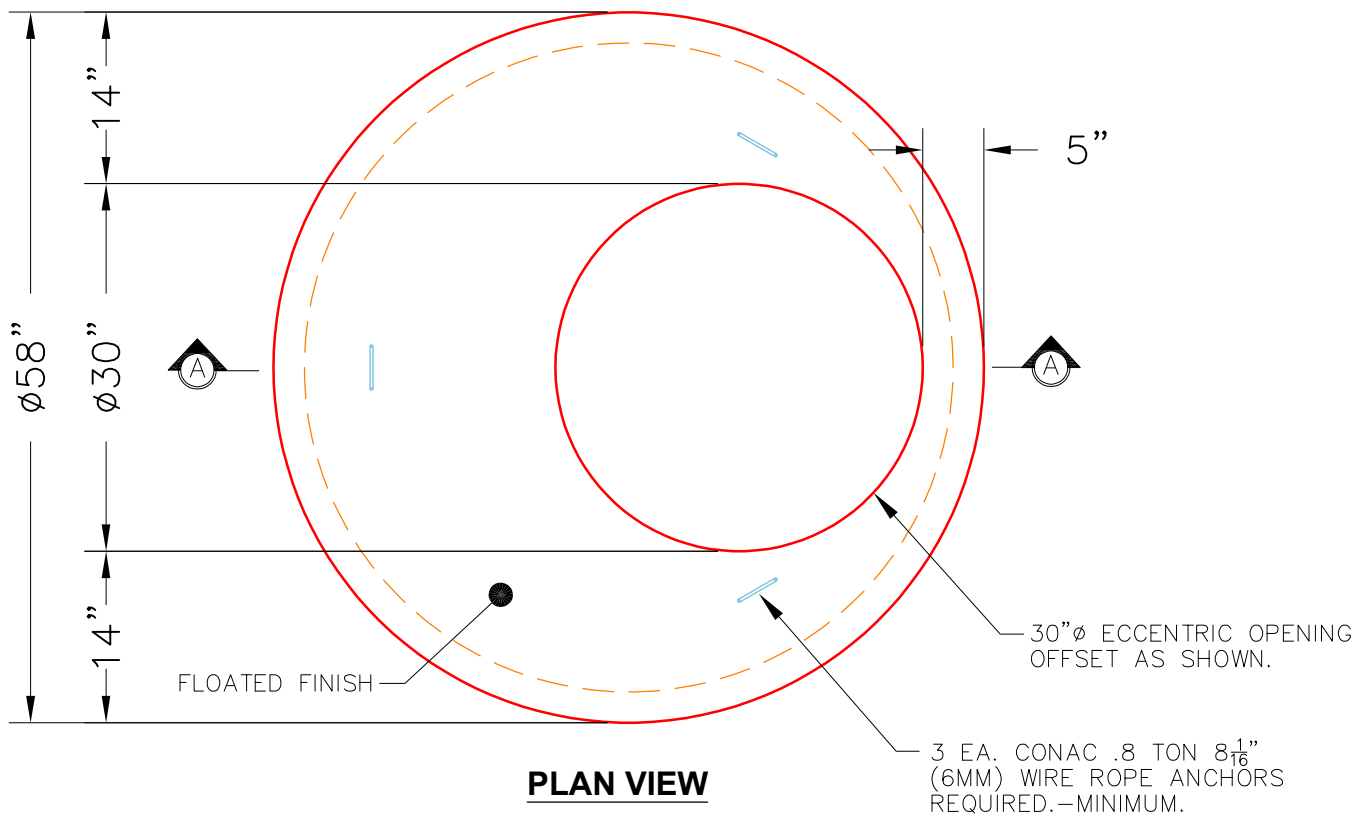

NOTES:

1. MANUFACTURED TO ASTM C-478 (LATEST REVISION).
2. CONCRETE: 5,000 PSI AT 28 DAYS.
3. REINFORCING: #4 BAR @ 10" O.C. E.W. (GRADE 60).

PRODUCTION WORK ORDER		PRODUCT I.D.: MH048LD12-30	DESCRIPTION: 48" ϕ X 12" MH TOP SLAB SPECIAL	
	QUALITY CONTROL CHECKLIST		PRODUCT VIEW: RIGHT SIDE UP	
	<input type="checkbox"/> ALL DIMENSIONS CORRECT.		CUSTOMER: CONTECH ENGINEERING SOLUTIONS	
	<input type="checkbox"/> LIFTERS INSTALLED.		PROJECT: 772445 WAWA 7602	
	<input type="checkbox"/> HOLE LOCATION CORRECT.		STRUCTURE: 10-CS-4	
	<input type="checkbox"/> REINFORCING CORRECT.		QUOTE/SALES ORDER NO: 25-4266	
	<input type="checkbox"/> FINISH ON SLAB SURFACE UNIFORM.		PC: T. SEKULA	
<input type="checkbox"/> OUTSIDE TOP EDGE TROWELLED.		DRAWING: J. COPPAGE		
<input type="checkbox"/> GROOVE JOINT INSTALLED.		DATE: 10/24/25		
QC CHECK INITIALS:		SCALE: NTS		
		PG. 1 of 1		