

Job Name: 25-4266 - 772445 WaWa 7602
 Job Location: Elizabethtown, KY
 Contractor: Contech Engineering Solutions

Plant: Beaver Dam
 10/24/2025 9:12:04 AM

Tech: J. Copping
 PC: T. Sekula



Structure ID: 10-CS-4

P2 MH048RSVF

MH RISER Custom Ht

- P4) 30" - CASTING HEIGHT - 4"
- P3) 48" - MH FLAT LID w/30in ECC Hole - 12"
- P2) 48" - MH RISER Custom Ht - 63"
- P1) 48" - MH BASE - 18"
- 1) PSASSEMBLY
- 1) CVSTENCILING
- 2) 48" - Conseal CS-102 1.00"
- 2) Hole - 28

Structure Notes:
 (4" TALL CASTING PROVIDED BY OTHERS)
 LIFTING ANCHORS TO BE INSTALLED ON THE OUTSIDE OF THE STRUCTURE
 ICAST TO INSTALL THE INTERNALS
 CONTECH'S LOGO AS WELL AS THE INLET AND OUTLET MUST BE STENCILED ONTO THE STRUCTURE

Structure Total: 7857 lb

Rim: 842.25' Rim to Invert: 4.43' Slack: 7.16" Sump: 51" Step Position:

Position	Elev	Angle	Ext. (cw)	Pipe	Pipe OD	Connector	Hole	Horz Size	Up ()	Offset
Invert 1	837.82'	270°	136.659"	18" RCP B WALL	23"	Hole 28	28"	29.896"	23.75"	0"
Invert 2	837.82'	90°	45.553"	18" RCP B WALL	23"	Hole 28	28"	29.896"	23.75"	0"
Invert 3										
Invert 4										
Invert 5										
Invert 6										
Invert 7										
Invert 8										

RIGHT-SIDE UP VIEW (int. dimensions)

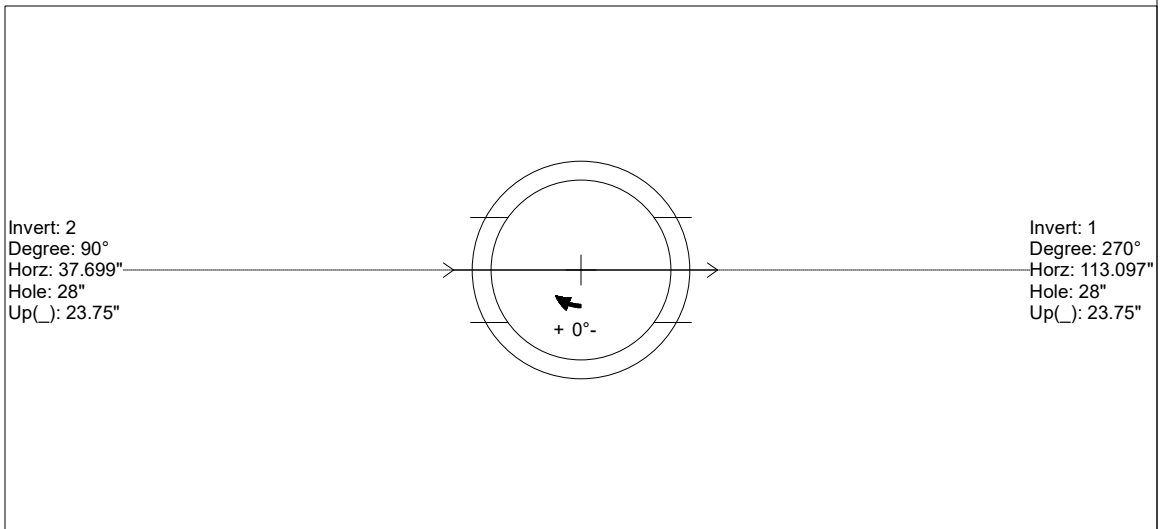
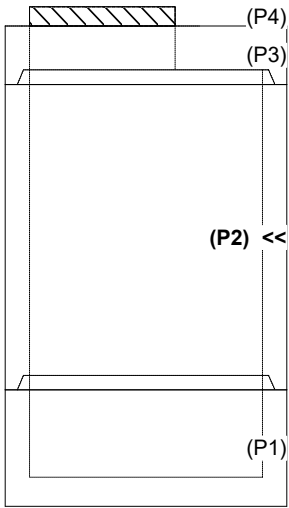

INSIDE WALL DIMENSIONS

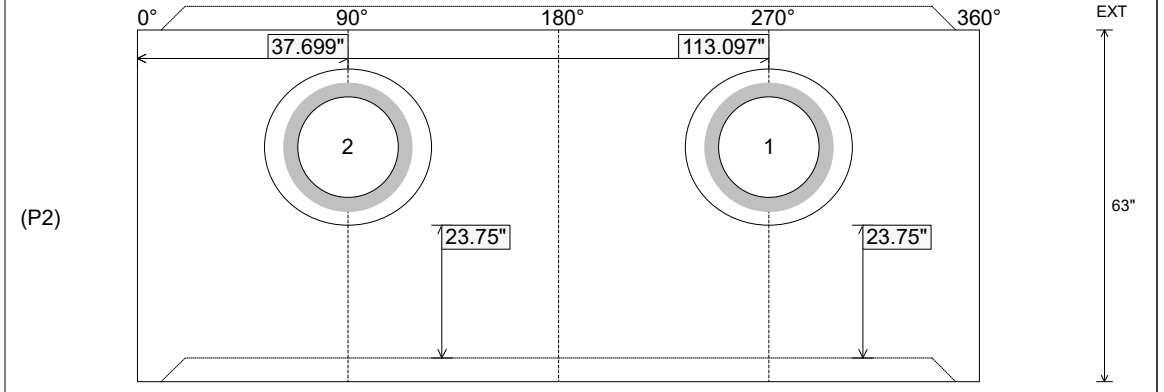

Coating (Int): Coating (Ext):	Seam Up: Tongue Seam Dn: Groove	Wall Thickness: 5" Floor Height: 0"	Height (Int): 63" Height (Ext): 63"	Weight (Net): 3856 lb Volume (Net): 0.98cu.yd
----------------------------------	------------------------------------	--	--	--