

Job Name: 25-4261 - Midsummer Street Extension
 Job Location: Bowling Green, KY 42101
 Contractor: Scott & Ritter, Inc.

Plant: 100

Tech: J. Horsley - F

1/29/2026 3:37:13 PM

PC: C. Goff



Structure ID: CBI B

P2 MH048LD07-24X36RECT

MH FLAT TOP w/24"x36" Hole F/F

- P3) 24" x 36" - CASTING HEIGHT - 6.5"
- P2) 48" - MH FLAT TOP w/24"x36" Hole F/F - 7"
- P1) 48" - MH BASE Custom Ht F/n - 40"
- 1) 48" - Conseal CS-102 1.00"
- 1) 24" x 36" - Conseal CS-102 1.00"
- 2) Hole - 32
- 1) Hole - 20
- 3) MH Step ML-10-TDS-NCR - 10"

0 lb
 1044 lb
 3263 lb
 0 lb
 0 lb
 0 lb
 0 lb
 0 lb
 0 lb

 4307 lb

Structure Total:

Structure Notes:

1. PER ASTM C-478 SPECIFICATIONS
2. CONCRETE: 4,000 PSI AT 28 DAYS
3. REINFORCEMENT: #4 BAR @ 10" C.C. E.W. (GRADE 60) - 2" MIN. REBAR CLEARANCE (TYP)
4. JBS 3080 FRAME, GRATE, & CURB HOOD SUPPLIED BY OTHERS
5. LIFTERS: 4 EA. WRA016 CONAC WIRE ROPE ANCHORS FOR PLANT & FIELD HANDLING
6. TOP SURFACE TO RECEIVE FLOATED FINISH

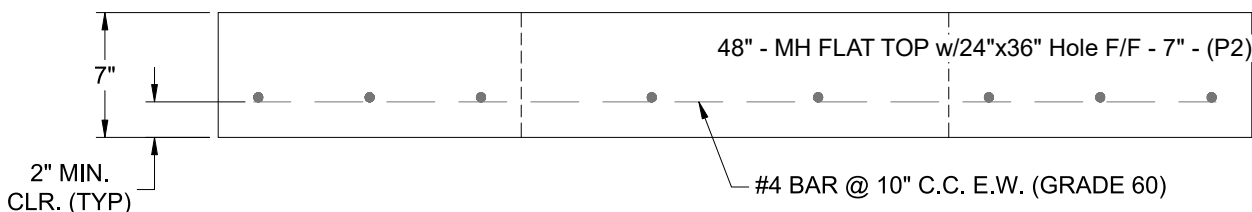
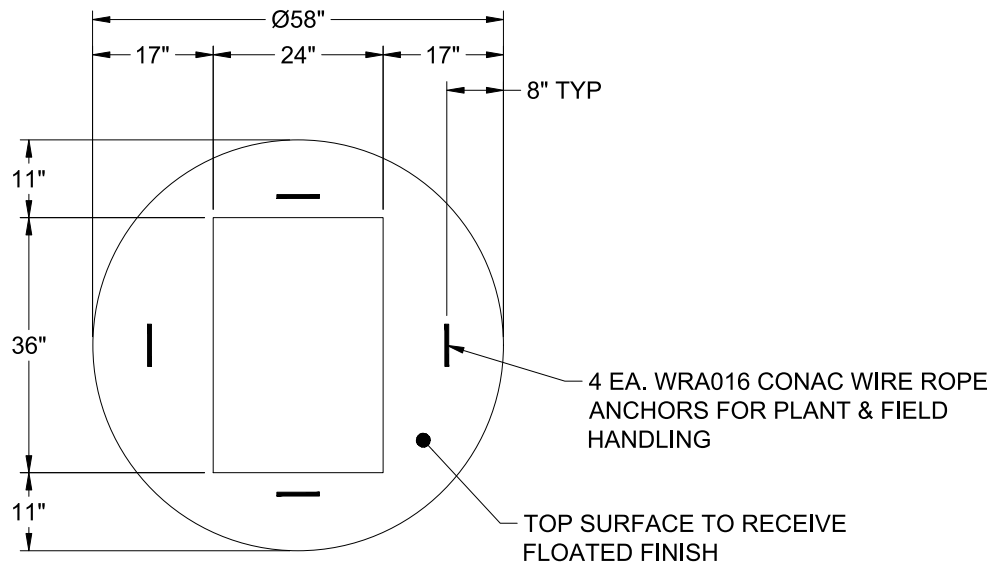

Coating (Int):
 Coating (Ext):

Seam Up: Flat
 Seam Dn: Flat

Wall Thickness: 5"

Height (Ext): 7"

Weight (Net): 1044 lb
 Volume (Net): 0.27cu.yd