

Job Name: 25-4257 - KYTC Pulaski Co Call 108 (254106)	Plant: 100	Tech: Jared - A	
Job Location: Somerset, KY Contractor: Weddle Enterprises, Inc	3/30/2026 8:52:04 AM	PC: Celina Goff	

Structure ID: 1875

P1 BX2436-08BVF

BOX BASE 8inW, 8inF, Variable Ht T/n

P3) 24" x 120" - CB INLET KY A 10' TOP RIGHT F/G - 10"	3398 lb
P2) 24" x 120" - CB INLET KY A 10' BOTTOM RIGHT T/G - 18"	5270 lb
P1) 24" x 36" - BOX BASE 8inW, 8inF, Variable Ht T/n - 35"	4721 lb
1) CASTING - HOE KY-206 F/C (KY TY1)	206 lb
1) This Structure Includes a Cast-in Item - KY-206 Frame Flange Side Up	0 lb
1) 24" x 36" - Conseal CS-102 1.00"	0 lb
1) Hole - 24"	0 lb
1) Hole - 6"	0 lb
Structure Total:	13595 lb

Structure Notes:
**** KYTC STATE PROJECT ****
 1. PER KYTC CBI TYPE A / ASTM C-913 SPECS
 2. CONCRETE: 4,000 PSI AT 28 DAYS
 3. REINFORCEMENT: #5 BAR @ 12" C.C. E.W. (GRADE 60) - 2" MIN. REBAR CLEARANCE (TYP)
 4. NO STORM INVERT
 5. NO STEPS
 6. HOE KY-206 FRAME & COVER "STORM" SUPPLIED BY ICAST - FRAME TO BE CAST INTO TOP PHASE TOP FLANGE SIDE UP

Rim: 963.87' Rim to Invert: 5.32' Slack: 0.84" Sump: 0" Step Position:

Position	Elev	Angle	Ext. (cw)	Pipe	Pipe OD	Connector	Hole	Horz Size	Up (_)	Offset
Invert 1	958.55'	180°	20"	18" HDPE	21.2"	Hole 24	24"	24"	-3"	0"
Invert 2	960.72'	180°	20"	4" HDPE (perf pipe)	4.8"	Hole 6	6"	6"	25"	0"
Invert 3										
Invert 4										
Invert 5										
Invert 6										
Invert 7										
Invert 8										

RIGHT-SIDE UP VIEW (int. dimensions)

UPSIDE-DOWN VIEW (int. dimensions)

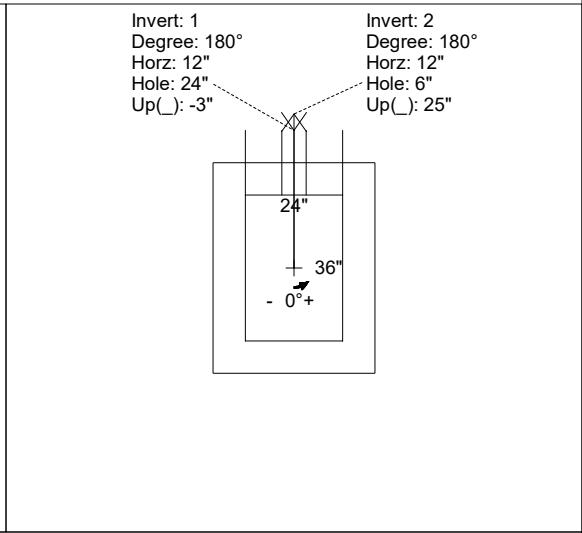
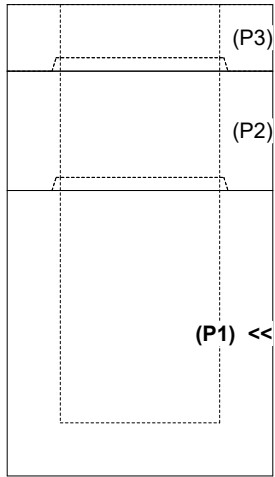

INSIDE WALL DIMENSIONS

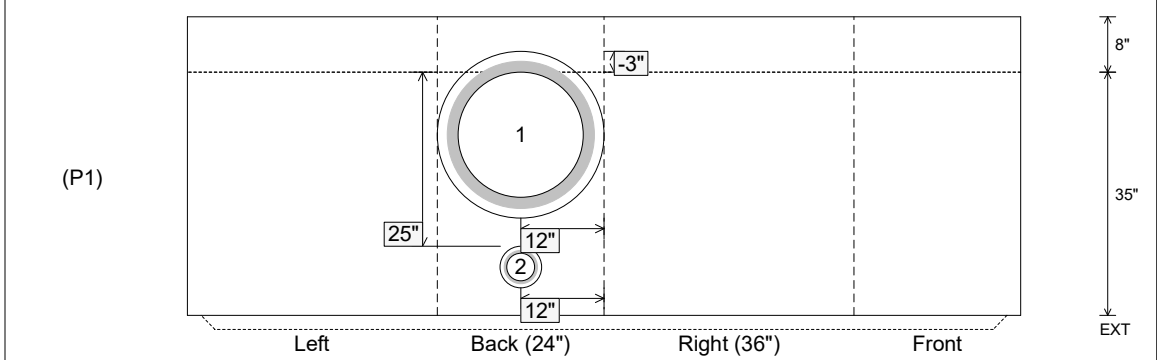

Coating (Int): Coating (Ext):	Seam Up: Tongue Seam Dn: n/a	Wall Thickness: 8" Floor Height: 8"	Height (Int): 35" Height (Ext): 43"	Weight (Net): 4721 lb Volume (Net): 1.21cu.yd
----------------------------------	---------------------------------	--	--	--