

Job Name: 25-4219 - Hitachi Berea
 Job Location: Berea, KY
 Contractor: Brown General Contractors

Plant: 100
 3/26/2026 1:10:30 PM

Tech: J. Horsley - F
 PC: J. Jarvis



Structure ID: ST-9

P1 MH048BAVF

MH BASE Custom Ht

- P3) 24" - CASTING HEIGHT - 7"
- P2) 48" - CON CONE w/24" HOLE - 36"
- P1) 48" - MH BASE Custom Ht - 38"
- 1) CASTING - HOE MCB-315-R F/G
- 1) 48" - Conseal CS-102 1.00"
- 2) Hole - 24"
- 6) MH Step ML-10-TDS-NCR - 10"

0 lb
 2252 lb
 3590 lb
 258 lb
 0 lb
 0 lb
 0 lb

 Structure Total: 6101 lb

Structure Notes:
 1. PER ASTM C478 SPECIFICATIONS.
 2. CONCRETE = 4,000 PSI AT 28 DAYS.
 3. NO INVERT CHANNEL.
 4. CASTING BY ICAST (HOE MCB-315R F/G).
 REINFORCING PER ASTM A615 (GRADE 60).
 - CONE (As .12)
 - RISER/WALLS (As .12)
 - FLOOR (As .31) #5 BARS AT 12" C.C.E.W.

Rim: 962.4' Rim to Invert: 6.79' Slack: 0.48" Sump: 0" Step Position: 90

Position	Elev	Angle	Ext. (cw)	Pipe	Pipe OD	Connector	Hole	Horz Size	Up ()	Offset
Invert 1	955.61'	0°	0"	18" HDPE	21.2"	Hole 24	24"	25.133"	-1.6"	0"
Invert 2	955.61'	265°	134.129"	18" HDPE	21.2"	Hole 24	24"	25.133"	-1.6"	0"
Invert 3										
Invert 4										
Invert 5										
Invert 6										
Invert 7										
Invert 8										

RIGHT-SIDE UP VIEW (int. dimensions)

UPSIDE-DOWN VIEW (int. dimensions)

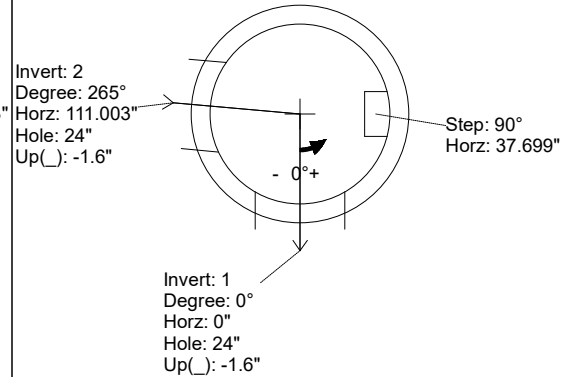
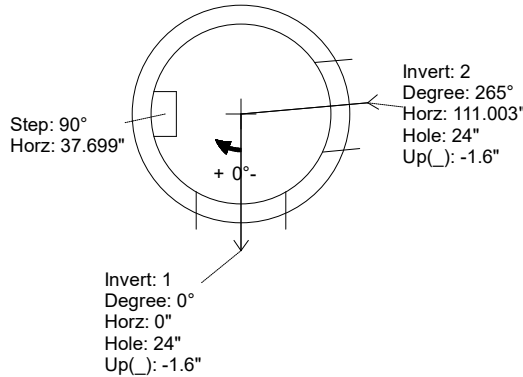
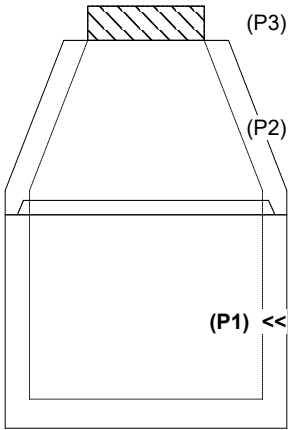

INSIDE WALL DIMENSIONS

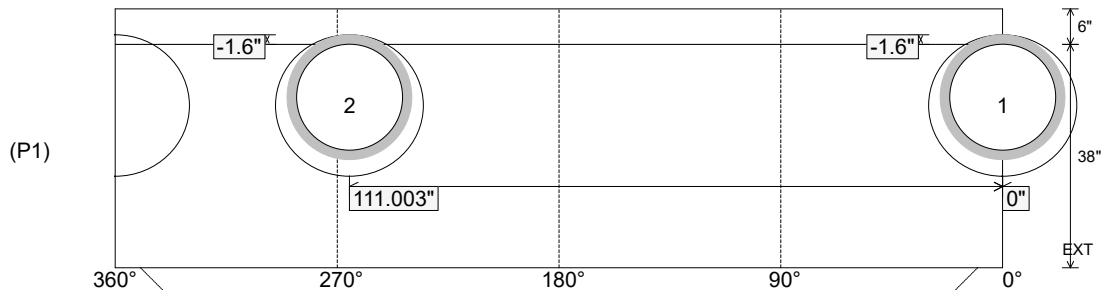

Coating (Int):
 Coating (Ext):

Seam Up: Tongue
 Seam Dn: n/a

Wall Thickness: 5"
 Floor Height: 6"

Height (Int): 38"
 Height (Ext): 44"

Weight (Net): 3590 lb
 Volume (Net): 0.92cu.yd